

SOFAR

# USER MANUAL

SOFAR 100...125KTLX-G4



Shenzhen SOFARSOLAR Co., Ltd.

**Shenzhen SOFARSOLAR Co., Ltd.**

11/F, Gaoxinqi Technology Building,  
District 67, XingDong Community, XinAn Street,  
Bao'An District, Shenzhen, China

SOFARSOLAR GmbH

Krämerstrasse 20

72764 Reutlingen

Germany

Email: [service.uk@sofarsolar.com](mailto:service.uk@sofarsolar.com)

Web: [www.sofarsolar.com](http://www.sofarsolar.com)

Document number

Issue 01 | 05.2023

English

# Content

<b>1</b>	<b>About this Manual</b>	<b>6</b>
1.1	Copyright declaration	6
1.2	Presentation of warnings	6
1.3	Presentation of action instructions	8
1.4	Note	8
<b>2</b>	<b>General Safety Information</b>	<b>9</b>
2.1	Intended use	10
2.2	Target group	10
2.3	Qualified personnel	10
2.4	Installation requirements	11
2.5	Transport requirements	11
2.6	Labelling on the device	11
2.7	Electrical connection	11
2.8	Operation	12
2.9	Repair and maintenance	12
2.10	Warranty	12
<b>3</b>	<b>About the Product</b>	<b>13</b>
3.1	Overview	13
3.2	Dimensions	13
3.3	Symbols and signs on the inverter	14
3.4	Power grid types	15
3.5	Functional features	15
3.6	Electrical block diagram	17
3.7	PID Recovery	17

- 4 Installation . . . . . 18**
  - 4.1 Before installation . . . . . 19
  - 4.2 Installation tools . . . . . 21
  - 4.3 Selecting an installation location . . . . . 22
  - 4.4 Installing the inverter . . . . . 24
  
- 5 Electrical Connections . . . . . 28**
  - 5.1 Terminal connector . . . . . 29
  - 5.2 Connect grounding PE cable . . . . . 29
  - 5.3 Connect grid side of inverter (AC-Output) . . . . . 31
  - 5.4 Connect PV side of inverter (DC-Input) . . . . . 36
  
- 6 Communication Connection . . . . . 39**
  - 6.1 USB port . . . . . 39
  - 6.2 COM port . . . . . 40
  
- 7 Commissioning . . . . . 47**
  - 7.1 Starting the inverter . . . . . 47
  - 7.2 Initial Setup . . . . . 47
  - 7.3 Smartphone app SOFAR setting . . . . . 48
  
- 8 Operation . . . . . 49**
  - 8.1 Control panel and display . . . . . 49
  - 8.2 Standard display . . . . . 50
  - 8.3 Status display . . . . . 50
  - 8.4 Menu structure . . . . . 51
  - 8.5 Software update . . . . . 54
  
- 9 Troubleshooting . . . . . 55**
  - 9.1 Ground fault alarm . . . . . 55
  - 9.2 Event list . . . . . 56
  
- 10 Maintenance . . . . . 66**
  - 10.1 Cleaning the inverter . . . . . 66
  - 10.2 Cleaning the heat sink . . . . . 66
  - 10.3 Fan maintenance and replacing a fan . . . . . 66

11 Technical Data ..... 69

11.1 Efficiency Curves ..... 71

11.2 Characteristics curves ..... 72

12 Declaration of Conformity ..... 76

# 1 About this Manual

This Installation and user manual (hereinafter referred to as the manual) describes the installation, electrical connection, commissioning, maintenance and fault elimination procedures of following products:

SOFAR 100KTLX-G4, SOFAR 110KTLX-G4, SOFAR 125KTLX-G4,  
SOFAR 125KTLX-G4-A.

- ▶ Carefully read this manual before use and retain it for future reference!
- ▶ Treat this manual as an integral component of the device.
- ▶ Keep this manual in close proximity to the device, including when it is handed over to another user or moved to a different location.

This manual contains important safety information on installation, operation and maintenance of the device.

- ▶ Read and observe all given safety information.

The products, services or features you purchased shall be subject to the company's commercial contracts and terms. All or part of the products and services described in this document may not within the scope of your purchase. Unless additional terms and conditions in your contract, the company does not make any statement or guarantee on the contents of this document.

## 1.1 Copyright declaration

The copyright of this manual is owned by SOFARSOLAR. It may not be copied – neither partially nor completely – by companies or individuals (including software, etc.) and must not be reproduced or distributed in any form, or with the appropriate means.

SOFARSOLAR reserves the right to final interpretation. This manual may be amended following feedback from users or customers.

Consult our website at: <http://www.sofarsolar.eu> for the latest version.

## 1.2 Presentation of warnings

This manual contains information on safe operation and uses symbols to ensure the safety of persons and property as well as the efficient operation of the inverter.

- ▶ Read through the following symbol explanations carefully in order to prevent injury or property damage.

## Warnsymbol

	<p>The general danger symbol warns of risk of serious injury when used with the signal words CAUTION, WARNING, and DANGER.</p>
-----------------------------------------------------------------------------------	--------------------------------------------------------------------------------------------------------------------------------

## Signalwords

<p><b>NOTICE</b></p>	<p>Indicates a danger that results in damage to or destruction of the inverter.</p>
<p><b>CAUTION</b></p>	<p>Indicates a hazardous situation which, if not avoided, could result in minor or moderate injury.</p>
<p><b>WARNING</b></p>	<p>Indicates a hazardous situation which, if not avoided, could result in death or serious injury.</p>
<p><b>DANGER</b></p>	<p>Indicates a hazardous situation which, if not avoided, will result in death or serious injury.</p>

## Sectional warnings

Sectional warnings refer to a complete section and are structured as follows:

<p> <b>WARNING</b></p>
<p><b>Type and source of danger</b>  <b>Consequences for non observance</b>          ► Avoiding the danger</p>

## Embedded warnings

Embedded warnings are part of an action sequence and are placed right before the dangerous step.

**WARNING** Combination of type/source of danger, consequences for non observance and avoiding the danger.

## 1.3 Presentation of action instructions

This table shows the sequence of Action steps

Symbol	Function
✓	This describes an action requirement
1. 2. 3.	This is the sequence of action steps that must be followed step by step
▶	This is a single action step
↳	This describes the result of the action

## 1.4 Note

Notes are presented in a grey bar.

Provides tips essential to the optimal operation of the product.



# 2 General Safety Information



This chapter details the safety information pertaining to the installation and operation of the device.

If you have any questions or problems after reading the following information, contact SOFARSOLAR.

Read and understand the instructions within this manual and familiarise yourself with the relevant safety symbols in this chapter before beginning with the installation of the device and eliminating any faults.

Before connecting to the power grid, you must obtain official authorisation from the local power grid operator in accordance with the corresponding national and state requirements. Furthermore, operation may only be carried out by qualified electricians.

Contact the nearest authorised service centre if any maintenance or repairs are required.

- ▶ Contact your dealer to obtain information about your nearest authorised service centre.
- ▶ Do NOT carry out repairs on the device yourself; this may lead to injury or property damage.
- ▶ Before installing the device or carrying out maintenance on it, you must open the DC switch in order to interrupt the DC voltage of the PV generator. You can also switch off the DC voltage by opening the DC switch in the Array junction box. Not doing this may result in serious injury.

## 2.1 Intended use

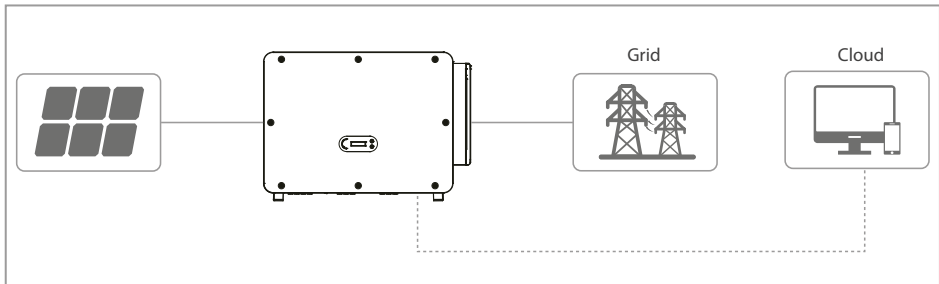

The SOFAR 100...125KTLX-G4 is a grid-coupled PV inverter with multiple MPPTs which converts the direct current generated by PV systems into a three-phase alternating current and feeds it into the public power grid. The AC circuit breaker and DC switch are used as a disconnecting device and must be easily accessible.

SOFAR 100...125KTLX-G4 inverters may only be used with photovoltaic modules which do not require one of the poles to be earthed. In normal operation, the operating current must not exceed the limits specified within the technical data. Only photovoltaic modules may be connected at the PV input of the inverter (no batteries or other power sources must be connected). The installation of the inverter and auxiliary equipment should be made by a qualified technician who is authorized to carry out such work.

## 2.2 Target group

This manual is intended for qualified electricians who are responsible for the installation and commissioning of the inverter in the PV system, as well as the PV system operators.

## 2.3 Qualified personnel

Personnel tasked with the operation and maintenance of the device must have the qualifications, competence and experience required to perform the described tasks, while also being capable of fully understanding all instructions contained within the manual. For safety reasons, this inverter may only be installed by a qualified electrician.

Requirements for qualified electricians:

- Personnel has received training on occupational safety, as well as the installation and commissioning of electrical systems.
- Personnel is familiar with the local laws, standards and regulations of the grid operator.

SOFARSOLAR assumes no responsibility for the destruction of property or any injuries to personnel caused by improper usage.

## 2.4 Installation requirements

- ▶ Install the inverter according to the information contained in the following section.
- ▶ Mount the inverter to a suitable object with a sufficient load-bearing capacity (e.g. walls, PV frames etc.) and ensure that the inverter is upright.
- ▶ Choose a suitable place for the installation of electrical devices.
- ▶ Ensure that there is sufficient space for an emergency exit which is suitable for maintenance.
- ▶ Ensure sufficient ventilation in order to guarantee an air circulation for the cooling of the inverter.
- ▶ Installation of SOFAR 100...125KTLX-G4 on-grid inverter must conform with laws, regulations, codes and standards applicable in the jurisdiction.
- ▶ Before connecting the product to the electrical utility grid, contact the local utility company for allowance.

## 2.5 Transport requirements

The factory packaging is specifically designed to prevent transport damage, i.e. violent shocks, moisture and vibrations. However, the device must not be installed if it is visibly damaged. In this case, notify the responsible transport company immediately.

The maximum stacking layer number cannot exceed 4 layers.

If the inverter be storage for more than half years, the inverter needs to be fully examined and tested by qualified service or technical personnel before using. For storage conditions see [Technical Data](#) on page 69.

## 2.6 Labelling on the device

- ▶ The labels must NOT be concealed by items and foreign objects (rags, boxes, devices, etc.). They must be regularly cleaned and kept clearly visible at all times. See chapter [About the Product](#) on page 13.

## 2.7 Electrical connection

- ▶ Observe all applicable electrical regulations when working with the Solar inverter.
- ▶ Before establishing the electrical connection, cover the PV modules using opaque material or disconnect the PV generator from the inverter. Solar radiation will cause dangerous voltage to be generated by the PV generator!
- ▶ All installations and electrical connections may only be carried out by trained electricians!
- ▶ Authorisation for grid feed-in. Obtain authorisation from the local power grid operator before connecting the inverter to the public power grid.

## 2.8 Operation

- ▶ Contact with the electrical grid or the device's terminals may result in an electric shock or fire!
- ▶ Do not touch the terminal or the conductor which is connected to the electrical grid. Follow all instructions and observe all safety documents that refer to the grid connection.
- ▶ While the inverter is being operated, several internal components will become very hot. Wear protective gloves! Keep children away from the device!
- ▶ The PV generator must be earthed in accordance with the requirements of the local power grid operator!
- ▶ For reasons of personal safety, we recommend that all PV module frames and inverters of the PV system are reliably earthed.
- ▶ Ensure that the input voltage does not exceed the maximum permissible voltage. Overvoltage may cause long-term damage to the inverter, as well as other damage that is not covered by the warranty!

## 2.9 Repair and maintenance

- ▶ Before carrying out any repair work, first switch off the AC circuit breaker between the inverter and power grid, and then the DC switch.
- ▶ After switching off the AC circuit breaker and the DC switch, wait a minimum of 5 minutes before starting any maintenance or repair work.
- ▶ Following the elimination of any faults, the inverter should be fully functional once more. Should any repairs be required, contact a local authorised service centre.
- ▶ The internal components of the inverter must NOT be opened without the relevant authorisation. Shenzhen SOFARSOLAR Co., Ltd. assumes no responsibility for any resulting losses or defects.

## 2.10 Warranty

- ▶ Do not open the inverter or remove any of the labels.

Otherwise, SOFARSOLAR shall assume no guarantee.

# 3 About the Product

## 3.1 Overview

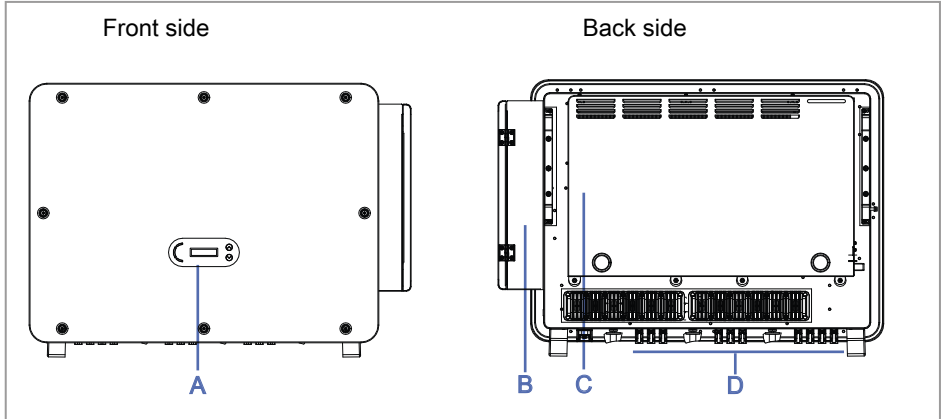

A	Control panel and display
B	AC connection box
C	Fan cooling box
D	DC connection board

## 3.2 Dimensions

SOFAR 100...125KTLX-G4

L × W × H = 970 x 695 x 325 mm

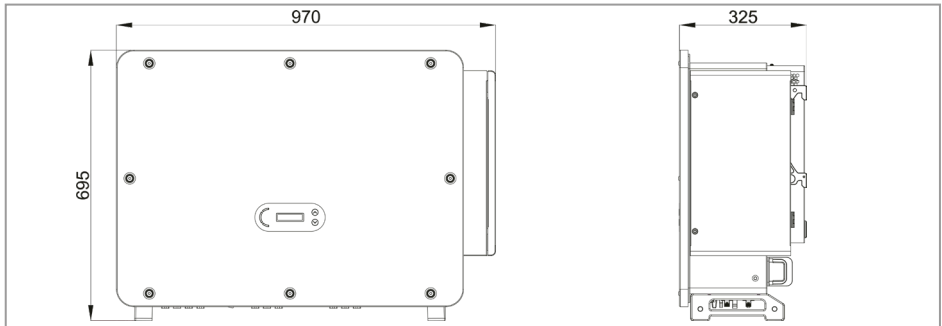

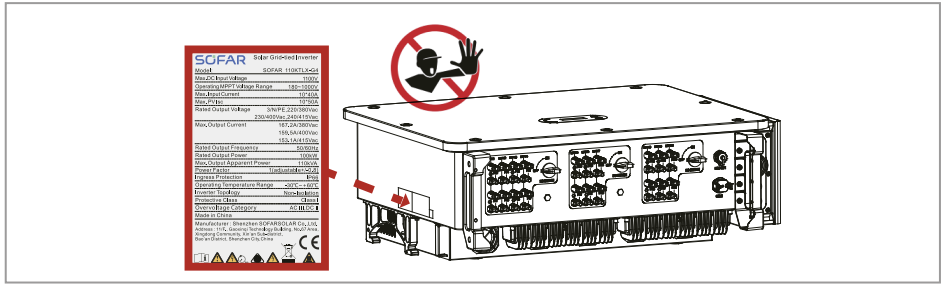

### 3.3 Symbols and signs on the inverter



Several symbols pertaining to safety can be found on the inverter. Read and understand the content of these symbols before starting the installation.

Symbol	Description
	Residual voltage is present in the inverter! Before opening the inverter, you should wait five minutes to ensure that the capacitor has been fully discharged.
	Caution! Danger through electric shock
	Caution! Hot surface
	The product is compliant with EU guidelines
	Earthing point
	Read the manual before installing the inverter
	Device degree of protection according to EN 60529
	Positive and negative poles of the DC input voltage
	The inverter must always be transported and stored with the arrows pointing upward

Symbol	Description
	The temperature range in which the inverter can operate
	RCM (Regulatory Compliance Mark) The product meets the requirements of the applicable Australian standards.

### 3.4 Power grid types

SOFAR 100...125KTLX-G4 are compatible with the following grid types:

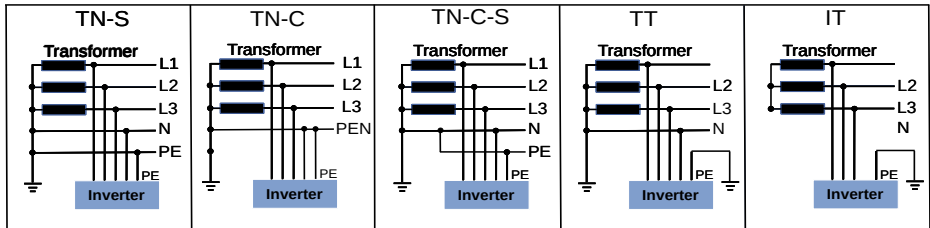

### 3.5 Functional features

The DC output generated by the PV generator is filtered by the input board before it reaches the power board. The input board also provides functions such as the detection of insulation impedance and the measurement of the DC current and voltage. The DC current is converted into AC current by the power board. The AC current is filtered by the output board and fed into the power grid. The output board also provides functions such as grid voltage and current measurement, earth fault protection and a disconnecting relay. The control board supplies the auxiliary energy, controls the operating state of the inverter and displays the operating status on the display board. An error code will appear on the display if the inverter is in an abnormal operating state. At the same time, the control board may trigger the relay in order to protect the internal components.

## Functions

### A. Digital inputs (DRMs)

The inverter can be switched on/off or the grid power can be controlled via the external control.

### B. Feeding of reactive power into the grid

The inverter is capable of generating reactive power and can also feed it into the grid. The setting of the power factor (Cos Phi) can be controlled via the serial RS485 interface.

### C. Limitation of the active power fed into the grid

The inverter can limit the active power fed into the grid to a specific value (as a percentage of the rated output).

### D. Output reduction at overfrequency within the grid

If the grid frequency is higher than the limit value, the inverter will reduce the output power; this is required to ensure stability of the grid.

### E. Data transfer

The inverter (or a group of inverters) can be monitored remotely via the RS485 communication bus or via WiFi/GPRS.

### F. Software update

The device supports local updates via USB stick and remote updates via WiFi/GPRS.

### G. PID recovery

The PID effect of PV modules can be recovered during night-time by applying a negative DC voltage to the PV Array.

### H. AFCI (Arc Fault Circuit Interruptor)

The inverter detects arc faults on the PV generator side and switches off to protect the system.

### I. IV Curve Scanning

The IV curve for each MPPT can be measured on demand and used in the monitoring portal to analyze potential issues in the PV array.

### J. Integrated grid relais

The relais can be operated by a central grid protection device to disconnect the inverter within 100 ms.



### 3.6 Electrical block diagram

SOFAR 100...125KTLX-G4 has 20 DC input strings. 10 MPPT tracker's that converts direct current of the PV array to grid-compliant, three-phase current and feeds it into the utility grid. Both DC and AC side has Surge Protection Device (SPD Type II).

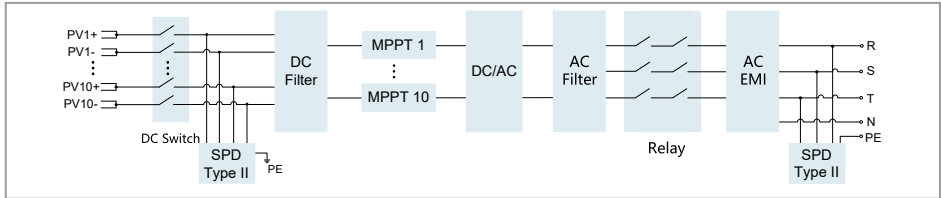

### 3.7 PID Recovery

When the inverter is running, the PID function module increases the potential between the negative pole of the photovoltaic array and the ground to a positive value to suppress the PID effect.

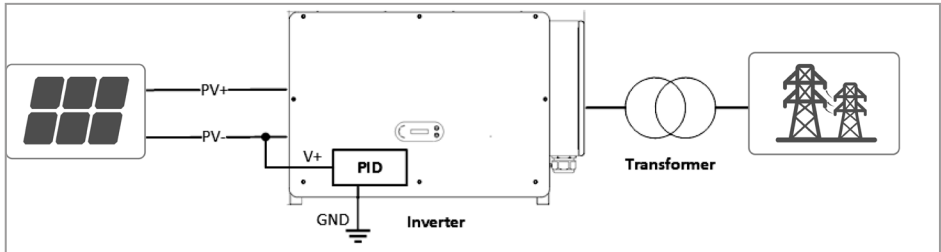

- Before enabling the PID recovery function, ensure that the polarity of the pv module's ground voltage meets requirements. If in doubt, contact the pv module manufacturer or read their corresponding User Manual.
- If the voltage scheme of the PID protection/recovery function does not meet the requirements of the corresponding PV module, the PID function cannot work properly or may even damage the PV module.
- Before enabling the reverse PID function, ensure that the inverter has been applied to the IT system.
- When the inverter is not running, the PID module will apply reverse voltage to the photovoltaic module to restore the degraded module.
- If the PID recovery function is enabled, the PID works only at night.
- After the PID recovery function is enabled, the PV series voltage to ground is 500Vdc by default. You can change the default value through the App.

# 4 Installation

## DANGER

### Hot surface of the inverter

**Risk of fire due to ignition of flammable materials from the hot surface of the inverter**

- ▶ Do not install the inverter on flammable material.
- ▶ Do not install the inverter in an area in which flammable or explosive material is stored.

## CAUTION

### Hot housing and heat sink of the inverter

**Risk of burns when touching hot surfaces of the operated inverter.**

- ▶ Do not install the inverter in places where it can be accidentally touched.

## CAUTION

### High weight of the inverter

**When falling down the inverter can cause injuries and may be damaged.**

- ▶ Take into account the weight of the inverter when transporting and moving it.
- ▶ Wear protection shoes when handling the inverter.
- ▶ Choose a suitable installation location and surface.
- ▶ Commission a minimum of two persons with the installation of the inverter.
- ▶ Do not set down the inverter upside-down.

## 4.1 Before installation

### Inverter Storage

If inverter is not installing immediately, storage condition need meet below requirements:

- Place inverter into the original package and leave desiccant inside, sealed tight with taps.
- Keep the storage temperature around  $-40 - +70$  °C, Relative humidity 0 – 95 %, no condensation (see chapter 11 [Technical Data](#) on page 69).
- The maximum stacking layer number cannot exceed 4 layers.
- If the inverter be storage for more than half years, the inverter needs to be fully examined and tested by qualified service or technical personnel before using.

### Checking the external packaging materials

#### NOTICE

##### Improper handling during transport

**Packging, inverter and components may be damage. Even if no external damage is visible, components inside the device may be damaged.**

- ▶ Check the external packaging material for damage, e.g. holes and cracks. If you discover any cases of damage, do not unpack the inverter and contact the transport company and/or dealer immediately.
- ▶ Do not install the inverter if the packaging was damaged.

- It is recommended that the packaging material should be removed within 24 hours before installing the inverter.
- Keep the original packaging and use it whenever the inverter needs to be shipped or transported.

## Unpacking the inverter

- ▶ Open the packaging and have at least two people grip underneath the inverter at both sides.
  - Do not put the inverter with wiring terminals contacting the floor because the power ports and signal ports are not designed to support the weight of the inverter.
  - When place inverter on the floor, put it above foam or paper to avoid the damage of the shell of inverter.

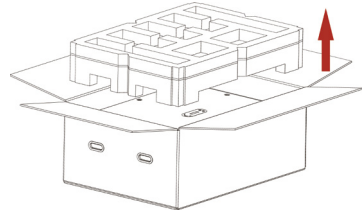

**CAUTION** The inverter is heavy and may fall down during transport. At least two people are required to lift it, or you can use a forklift. Keep your balance when lifting the inverter.

- ▶ Lift the inverter out of the packaging and move it to its installation position horizontally.

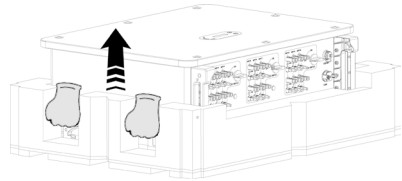

## Checking the delivery scope

- ▶ Check that the delivery is intact and complete.

In the event of any damage or missing components, contact the wholesaler.

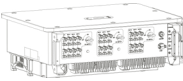

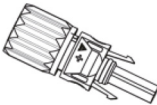



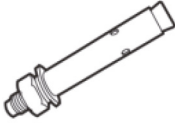



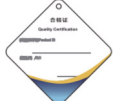

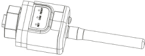

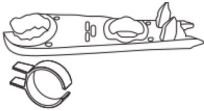
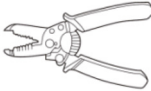



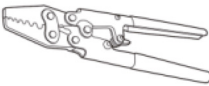

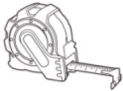
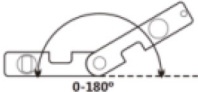
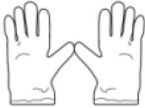

Image	Qty	Description	Image	Qty	Description
	1	SOFAR 100KTLX-G4 ... 125KTLX-G4		1	Rear Panel
	20	PV+ input connector		20	PV- input connector
	20	PV+ metal pin		20	PV- metal pin

Image	Qty	Description	Image	Qty	Description
	4	M6x30 Hexagon screws		2	M6x30 Hexagon screws
	1	Manual		1	Warranty Card
	1	Outgoing inspection report		1	Quality Certificate
	1	COM 16pin connector		1	USB collection (WiFi / Ethernet)

## 4.2 Installation tools

Required tools for installation and electrical connection as following table:

	Hammer drill		Screwdriver
	Removal tool		Wire stripper
	Crescent wrench		Hammer
	M6 Allen key		Socket wrench

	Crimping tool		Multimeter
	Marker		Measuring tape
	Spirit level		ESD gloves
	Safety goggles		Anti-dust respiratory mask

### 4.3 Selecting an installation location

Requirements for install position:

- Install position must not obstruct the disconnect of power.
- Place inverter in an appropriate bearing capacity objects.
- Location should be avoid touch by children.

Choose a suitable position for the installation of the inverter. Ensure that the following requirements have been fulfilled:

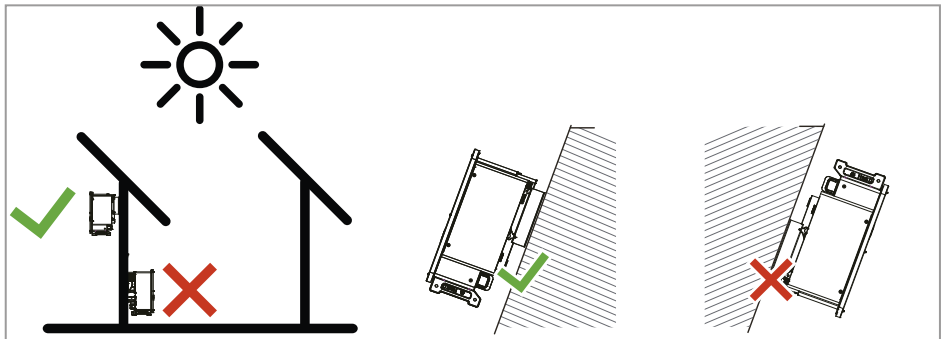

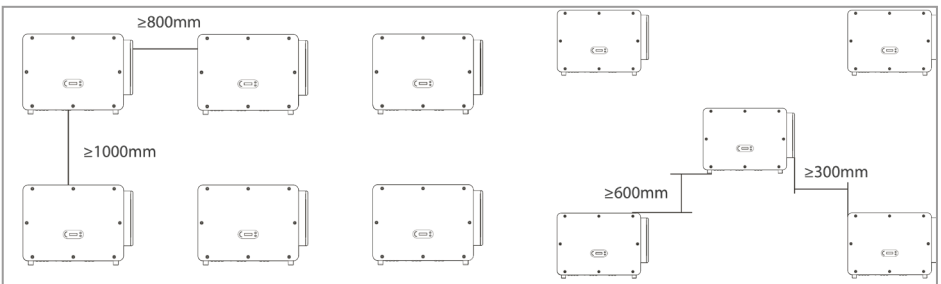
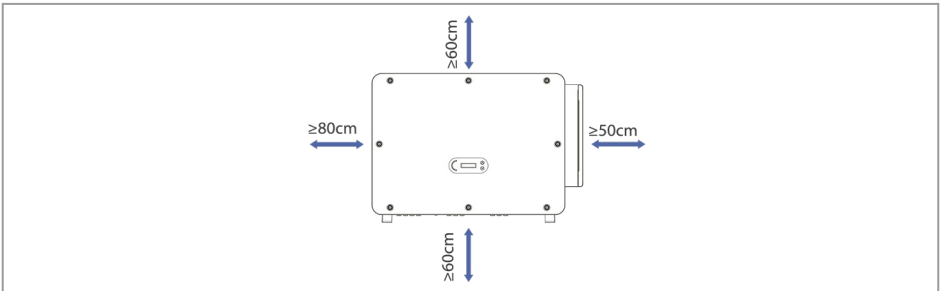
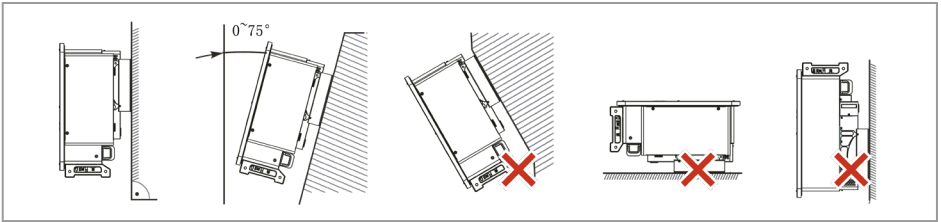
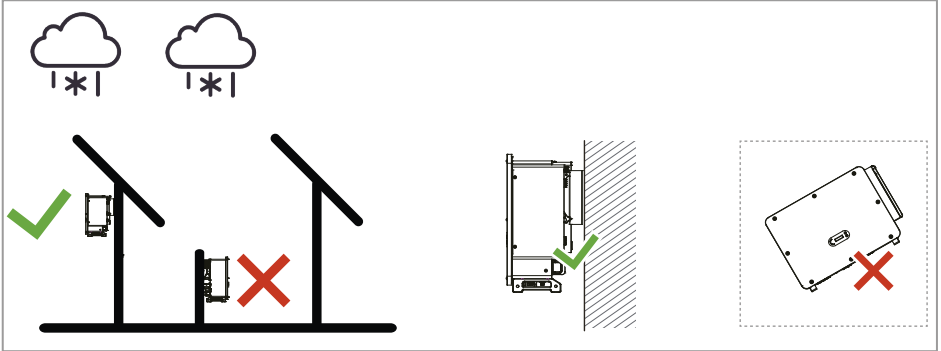

## 4.4 Installing the inverter

### Installing the bracket on a wall

1. Place the bracket on the mounting wall, determine the mounting height of the bracket and mark the mounting poles accordingly. Drilling holes by using Hammer Drill, keep the hammer drill perpendicular to the wall and make sure the position of the holes should be suitable for the expansion bolts.

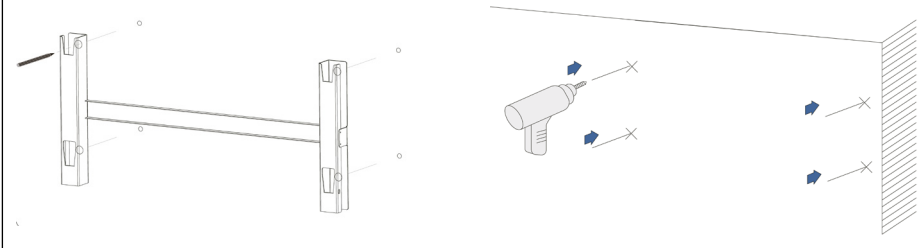

2. Insert the expansion bolt vertically into the hole.

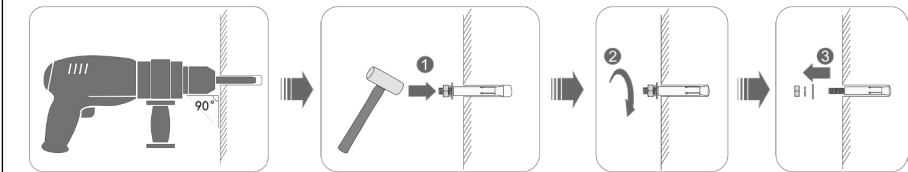

3. Align the bracket with the hole positions, fix the rear panels on the wall by tightening the expansion bolt with the nuts.

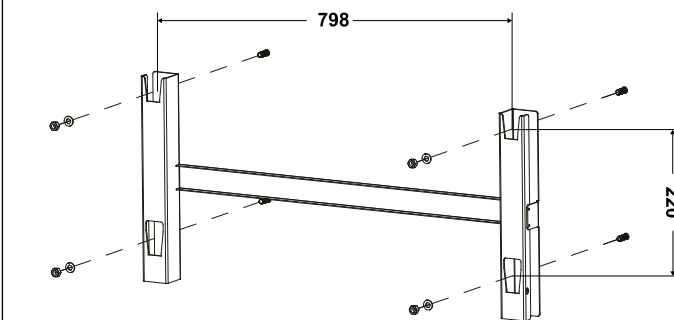



4. Lift the inverter and hang it on the bracket, and fixing both sides of inverter with M6 screw (accessories).

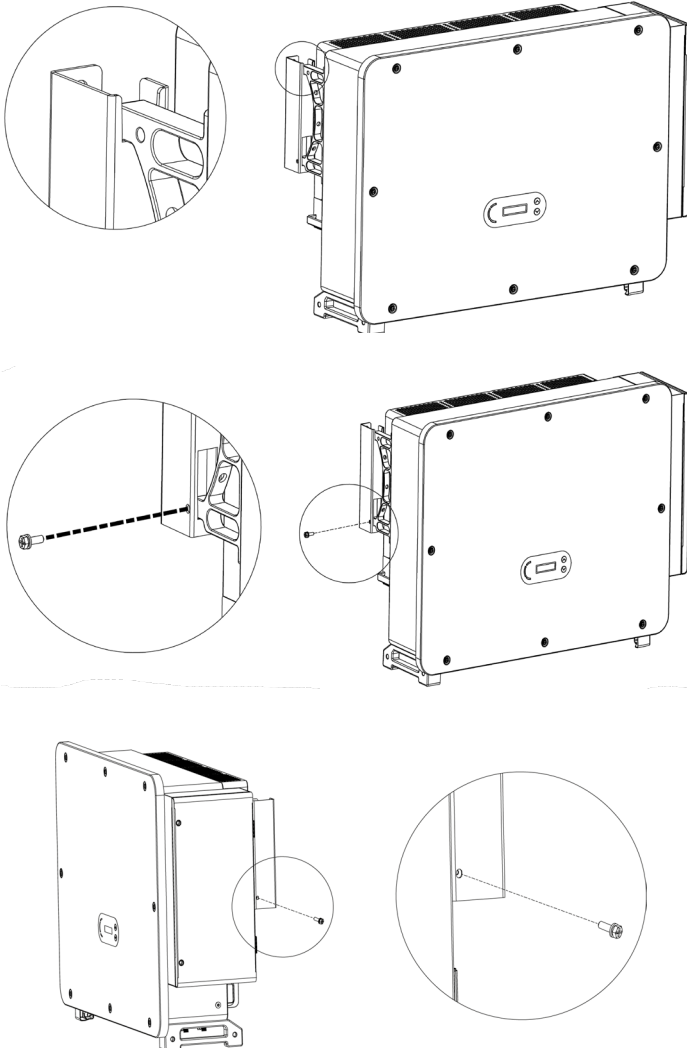

## Installing the bracket on a stand

1. Use wall mount bracket, ensure the pole position are in same level by using level rule and mark the holes.

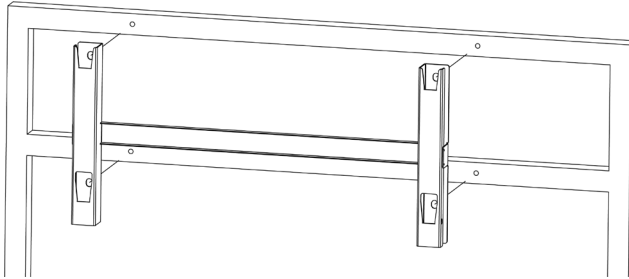

2. Drilling holes by using a Hammer Drill.

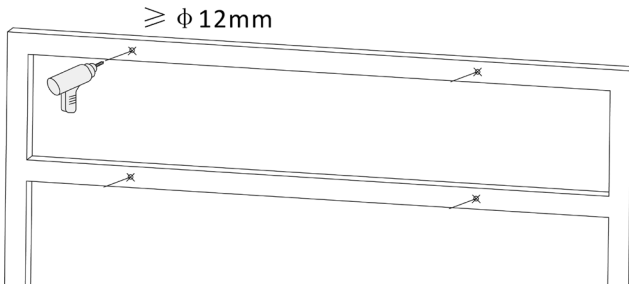

3. Use M10 screw and M10 flat washer to secure the wall bracket.

M10 x 50 screw and M 10 flat washer need self-preparation.

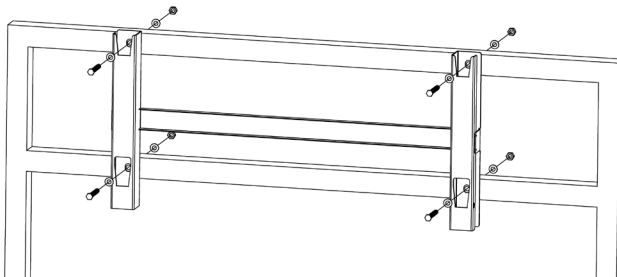

4. Lift the inverter and hang it on the wall bracket, then fixing both sides of Inverter with a M6 screw. See step 4 on page 24.

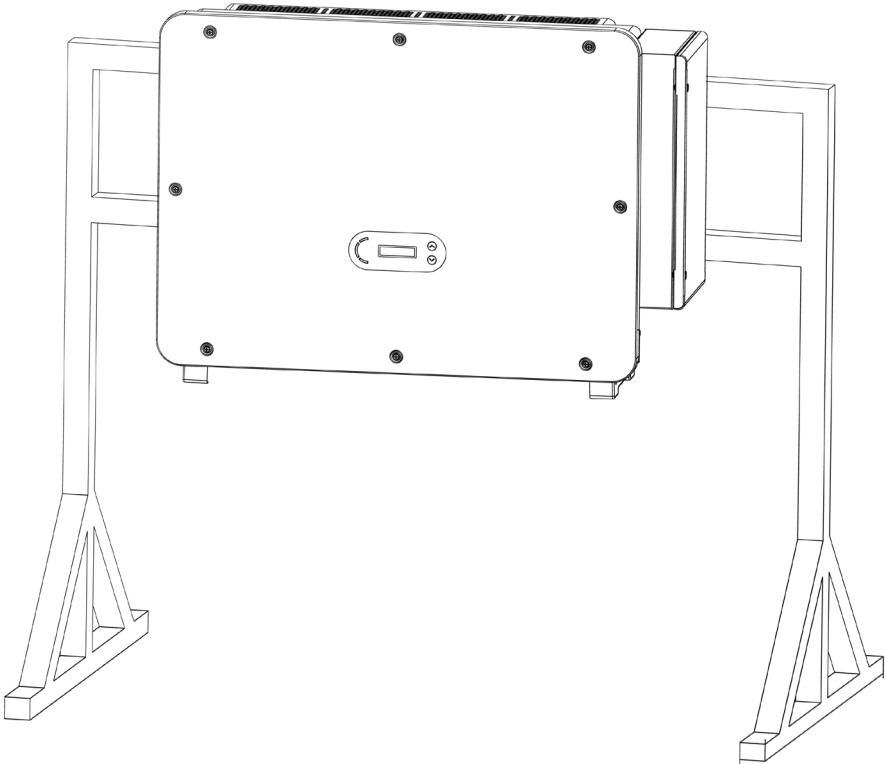

The stand must be firmly anchored to the ground to avoid shaking and tipping.

# 5 Electrical Connections

## DANGER

### Dangerous electrical voltage at the DC connections

Even when switched off touching the DC connection of the inverter will cause a lethal electric shock.

- ▶ Reason is that the electrical charge remains in the capacitor after the DC switch has been switched off. Therefore, at least 5 minutes must lapse before the capacitor has been electrically discharged.
- ▶ PV modules generate electrical energy when exposed to sunlight, and this may present an electrical shock hazard. DC voltages on the PV array can reach up to 1100 V.

## NOTICE

### Open circuit voltage outside of permissible range

Open circuit voltage outside of permissible range can destroy the inverter.

- ▶ Open circuit voltage of the PV strings should not exceed 1100 V (see [Technical Data](#) on page 69).

Model	Max. PV / Panel ISC	Max. AC output current at Nominal Grid Voltage		
		380 VAC	400 VAC	415 VAC
SOFAR 100KTLX-G4	25A per String / 50 A per MPPT	152.0 A	145.0 A	139.2 A
SOFAR 110KTLX-G4		167.2 A	159.5 A	153.1 A
SOFAR 125KTLX-G4/G4A		190.0 A	181.2 A	174.0 A

## Connection sequence

- ✓ The connected PV modules must be compliant with IEC 61730 class A.

Electrical installation is performed as follows:

1. Connect PE cable
2. Connect DC input cable
3. Connect AC output power cable
4. Connect communication cable (optional)

## 5.1 Terminal connector

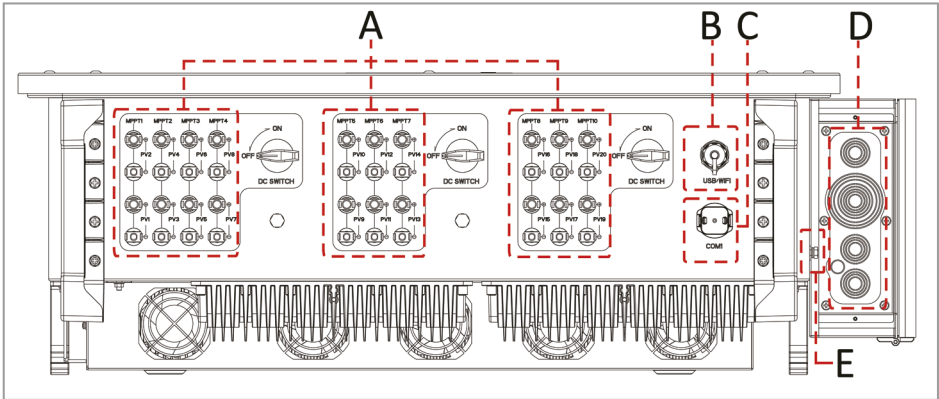

No	Label	Description
A	PV1...20 (+/-)	PV array connection
B	WIFI	USB Firmware update or Stick Logger connection
C	RS485/DRMs	RS485 network for external data logger or PV Park controller / remote power control and shut down
D		AC grid connection
E		Connecting terminal of the ground, choose at least one for grounding connection

## 5.2 Connect grounding PE cable

### NOTICE

#### Damage of the inverter due to not permissible pole grounding inverter failure due to grounding the plus and minus poles

- ▶ SOFAR 100...125KTLX-G4 is a transformerless inverter which requires the positive pole and negative pole of the PV array are NOT grounded.
- ▶ In the PV system, all non-current-carrying metal parts (such as mounting frame, combiner box enclosure, etc.) must be connected to ground.

1. Remove the insulation of the cable. For outdoor use, cables of  $> 16\text{mm}^2$  are recommended for grounding.
2. Crimp the cable to the ring terminal.

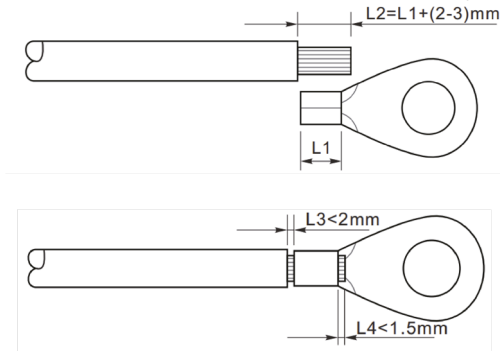

3. Remove the screw from the bottom side of inverter, connect the grounding cable to the grounding point and tighten the screw. Torque is 6–7 Nm.
  - A: M8 Hexagon screw
  - B: Grounding cable

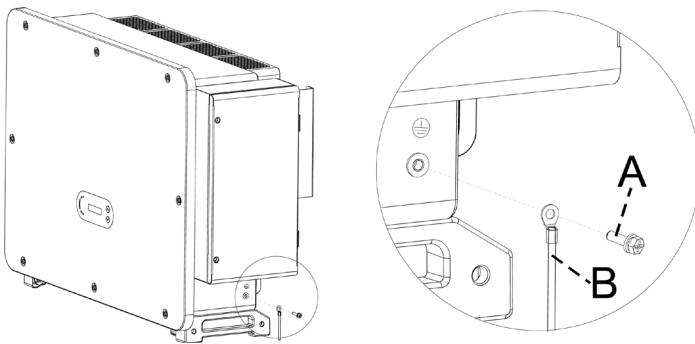

For improving anti-corrosion performance, after ground cable installed, apply silicone or paint is preferred to protect.

### 5.3 Connect grid side of inverter (AC-Output)

Follow the national rules and regulations for the installation of external relays or circuit breakers!

A residual current monitoring unit (RCMU) is integrated into the inverter. It detects leakage currents above 300 mA and disconnects from the grid for protection. For external Residual Current Devices (RCD), the rated residual current should be 300 mA or higher.

Connect the inverter to the AC power distributor or the power grid using AC power cables.

Each inverter must have its own circuit breaker.

Do not connect any consumers between the inverter and circuit breaker!

The AC disconnecting device must be easily accessible.

Inverter AC side should connect a three phase circuit current to ensure inverter can be cut off with utility grid for abnormal condition.

The AC cable need to meet the requirement of local grid operator.

#### Open the wiring box

Do not open the front cover of the inverter.

Before open the wiring box, please ensure DC and AC power is off.

Prevent rain or snow from entering the connection box.

Don't leave any items inside the connection box.

1. Use M6 screw driver to unscrew the two screws on the wiring box.

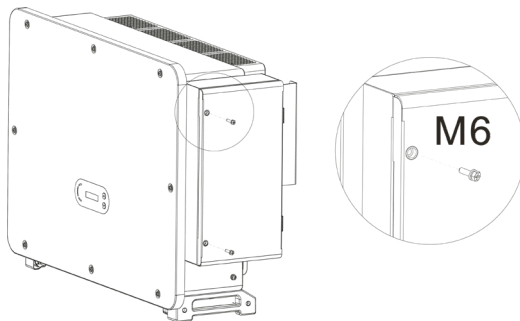

2. Open wiring box cover.

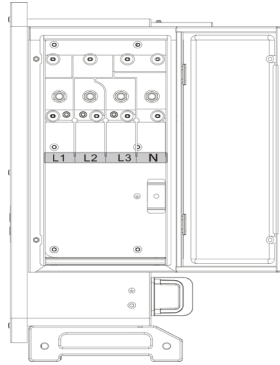

## Connection requirements

Ensure before connect to grid that the grid voltage and frequency of local grid meet the requirement of inverter, any question seek local grid company for help.  
 Connect the inverter only to grid after get the permission from local grid company.  
 Do not connect any loads between inverter and AC circuit breaker.

## Connection requirement

Cable type	Terminal connector type
Copper core cable	Copper terminal connector
Copper clad aluminum cable	Copper terminal connector
Aluminum core cable	Copper and aluminum transition terminal connector or aluminum terminal connector



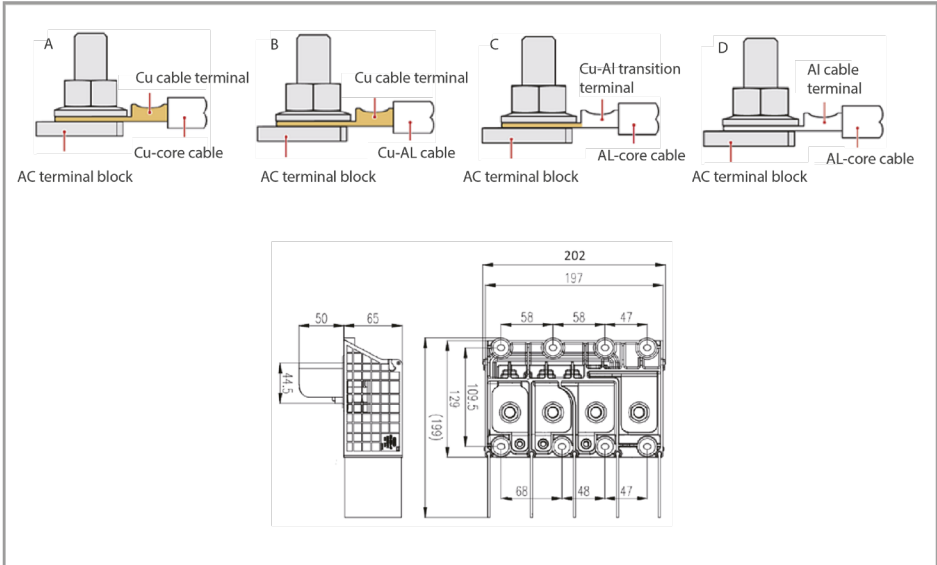

## Wiring Procedure

Requested cable dimensions SOFAR 100 – 125KTLX-G4

Cable cross-sectional area of L/N:	Copper Wire:95 – 185 mm <sup>2</sup> Aluminum Wire:120 – 240 mm <sup>2</sup>
Cable cross-sectional area of P/E:	16 – 35 mm <sup>2</sup>
Multi-core cable O.D. range:	≤60 mm
Single-core cable O.D. range:	≤32 mm

1. Open the cover, see [Open the wiring box](#) on page 31.
2. Turn OFF the AC circuit breaker and secure against reconnection.
3. Unscrew the nut of the AC terminal block and select the sealing ring according to the outer diameter of the cable. Insert the nut, sealing ring into the cable in sequence.
4. Remove the insulation layer of an appropriate length according to figure below.

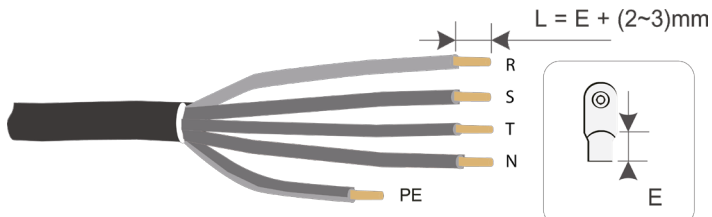

5. Crimp the Terminal.

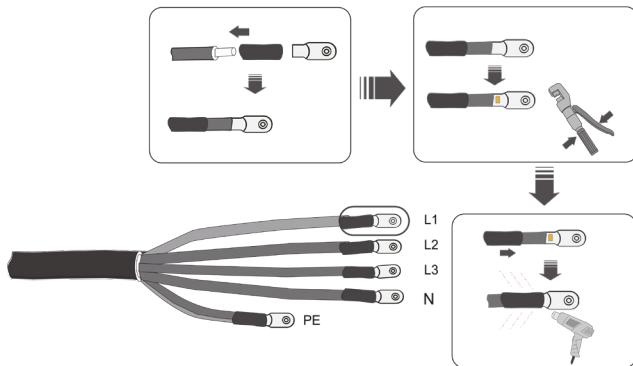

- 6. Depending on the grid configuration, connect L1, L2, L3 and N to the terminals according to the label and tighten the screw on the terminal using a screwdriver.

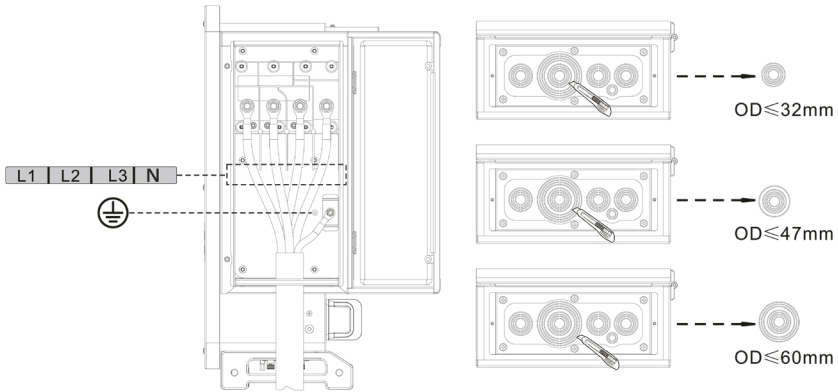

single core cable is wired as follows:

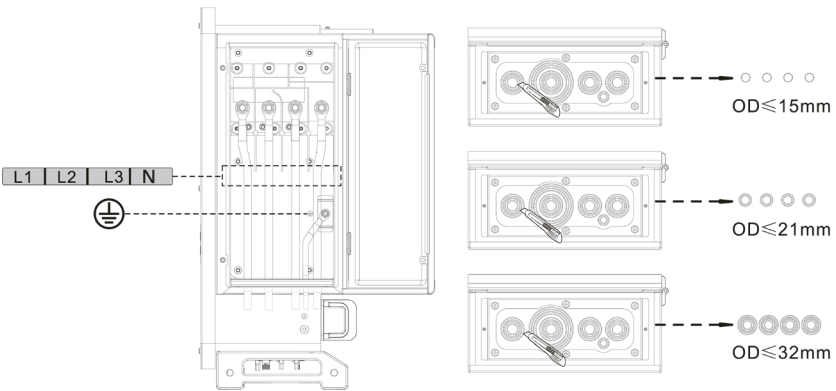

Phase lines use M12 terminal connector, PE line use M8 terminal connector. The position of "PE" Line and "N" Line should not be opposite. Opposite position may cause inverter permanently faulty.

- 7. Close wiring box cover, and tighten the screw.

## 5.4 Connect PV side of inverter (DC-Input)

Connecting PV strings into inverter must following the below procedure. Any faulty cause by inappropriate operation will be not included in the warranty.

- ▶ Ensure the maximum short circuit current of PV strings must be less than the maximum inverter DC current input. And three “DC switch” is in OFF position. Otherwise, it may cause high voltage and electric shock.
- ▶ Ensure PV array have good insulation condition in any time.
- ▶ Ensure same PV string must have the same structure, including: same model, same number of panels, same direction, same azimuth.
- ▶ Ensure PV positive connector connects to inverter positive pole, negative conenctor connect to inverter negative pole. Use the connectors in the accessories bag. The damage caused by incorrect is not included in the warranty.

Copper cable cross section area ( mm <sup>2</sup> )		Cable OD(mm)
Range	Recommend	
4.0 – 6.0	4.0	4.5 – 7.8

1. Use the metal contact pins from the accessories bag.
2. Connect the cable according below diagram (1.Positive cable, 2. negative cable). **CAUTION** danger of reverse polarity, use the corresponding contact pins, ensure that the polarity is correct before plugging into the DC connections!
3. Insert the positive and negative DC cables into the corresponding contact pins.

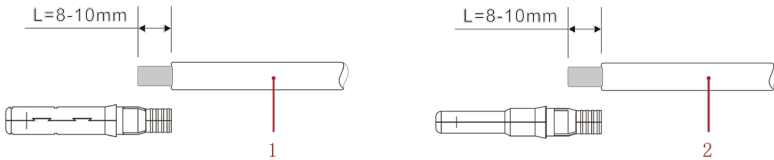

**1 Positive DC cable / 2 Negative DC cable**

4. Crimp the PV metal contact pin to the striped cable using a proper crimping pliers.

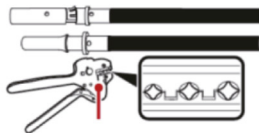

**CAUTION** danger of reverse polarity. Use the corresponding connector housing. Ensure that the polarity is correct before plugging into the DC connections!

- 5. Insert the crimped DC cables into the corresponding connector housing until you hear a **clicking** sound.

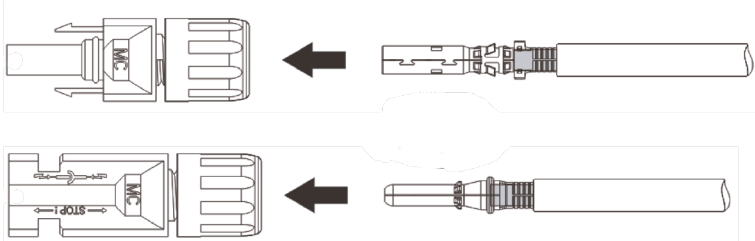

- 6. Connect the DC connector to the inverter.

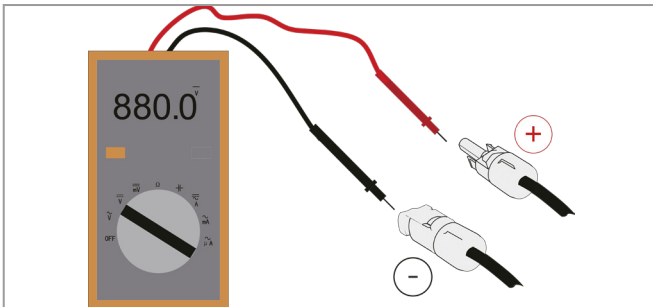
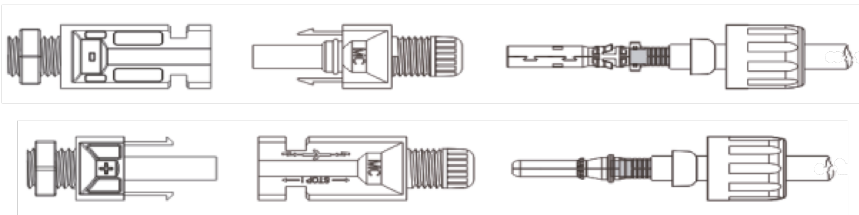

Use multimeter to make sure the PV array positive pole and negative pole!  
If need to remove the PV connector from inverter side, use the Removal Tool as below figure, move the connector gently.

**Remove the plus and minus connection from the inverter**

**CAUTION** Danger of DC arcing. Set the DC switch to OFF before removing the plus and minus connector.

- ▶ Insert a removal key into the locking and press on the key with the adequate force.

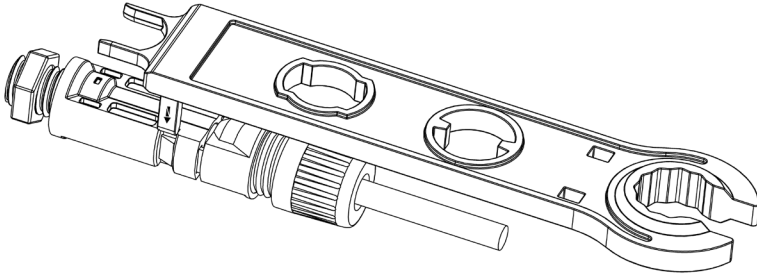

# 6 Communication Connection

When layout the cable routing, separate the communication wiring and power wiring because the signal can be affected.

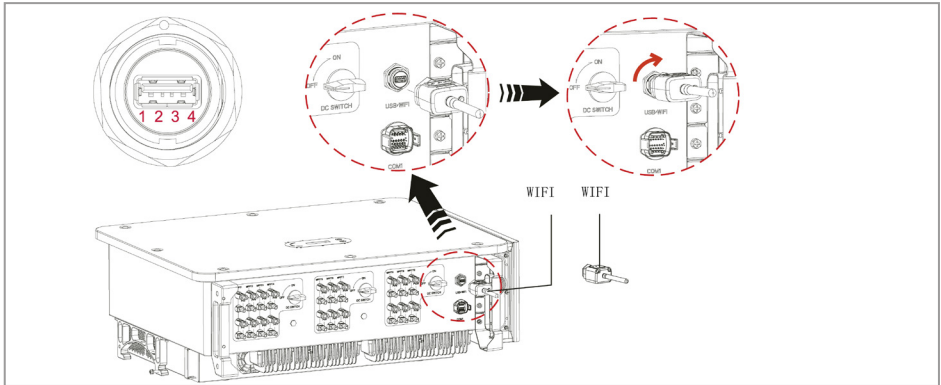

## 6.1 USB port

The USB port can be used to update the inverter's software version, or for connecting a WiFi-stick or Ethernet cable.

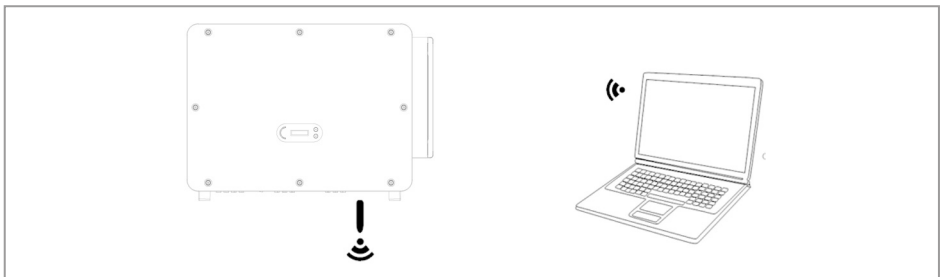

## 6.2 COM port

Recommend com cable size:

Name	Type	Outer diameter (mm)	Area (mm <sup>2</sup> )
RS485 Communication Wire	Outdoor shielded twisted pair meets local standards	3core : 4 – 8	0.25 – 1

Procedure:



Port Description (COM 1):

Pin	Name	Function	Note
1	RS485A	RS485 signal+	Inverter monitoring and system control
2	RS485A	RS485 signal+	
3	RS485B	RS485 signal-	
4	RS485B	RS485 signal-	
5	Electric meter RS485A	Electric meter RS485 signal+	Smart meter port
6	Electric meter RS485B	Electric meter RS485 signal-	
7	GND.S	Communication Ground	Logic interface for power control and remote-shutdown
8	DRM0	Remotesutdown	
9	DRM1/5		
10	DRM2/6		
11	DRM3/7		
12	DRM4/8		
13	CAN-3A	CAN+	For parallel
14	CAN-3B	CAN-	For parallel
15	CAN-3A	CAN+	For parallel
16	CAN-3B	CAN-	For parallel



## Logic Interface: DRMs, Power Control and remote shutdown

The DRM/Logic interface is used to control the inverter by external signals, usually provided from grid operators with ripple control receivers or other means. The logic interface inputs are defined according to different standard requirements.

The grid protection relays can trigger the internal grid relays to open within 150 ms.

The DRM0 inputs need a 15kΩ resistor in series to the input to feed-in power!

## DRMs for AS/NZS 4777.2:2015 and AS/NZS 4777.2:2020

Also known as Inverter Demand Response Modes (DRMs).

The inverter recognises all supported Demand Response commands and initiates the reaction within two seconds. The inverter remains in the reduced power mode as long as the input is closed.

Supported DRM commands are pre-configured: DRM0, DRM5, DRM6, DRM7, DRM8:

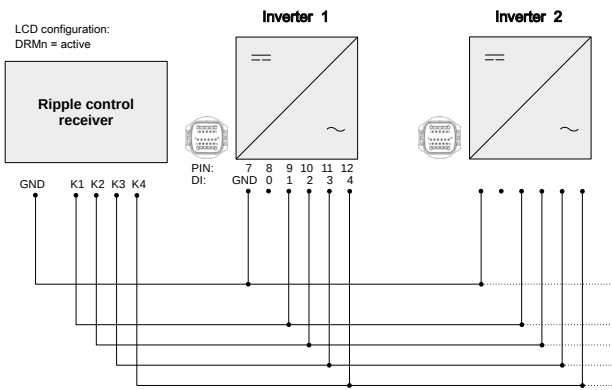
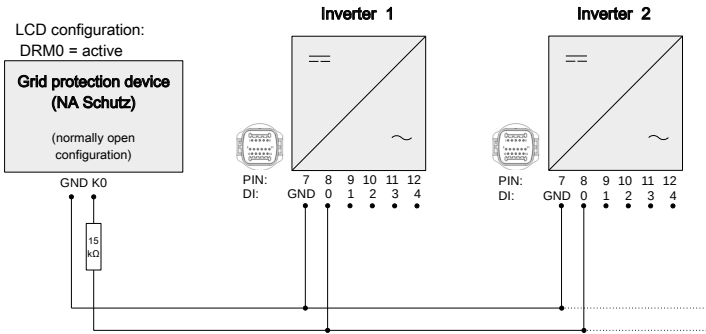

Function	Pin	Definition	Note	Digital Input
Grounding	7	GND.S	Signal GND	
DRMs/Logic Interface	8	DRM0	Remotesutdown	
	9	DRM1/5	0% power feed-in	DI 5
	10	DRM2/6	50% power feed-in	DI 6
	11	DRM3/7	75% power feed-in	DI 7
	12	DRM4/8	100% power feed-in	DI 8

## Logic interface for VDE-AR-N 4105:2018-11

This function serves to control and/or limit the output power of the inverter. The inverter can be connected to a radio ripple control receiver in order to dynamically limit the output power of all inverters within the system. The inverter remains in the reduced power mode as long as the input is closed.

Function	Pin	Definition	Note	Digital Input
Grounding	7	GND.S	Signal GND	
DRMs/Logic Interface	8	DRM0	Remotesutdown	
	9	DRM1/5	0% power feed-in	DI 5
	10	DRM2/6	30% power feed-in	DI 6
	11	DRM3/7	60% power feed-in	DI 7
	12	DRM4/8	100% power feed-in	DI 8

## Remotesutdown for EN50549-1:2019/VDE ARN 4105:2018-11

The inverter can be disconnected from the grid within 100 ms by an external signal. To use this function the DRM0 input is used. As long as the input is closed (the 15 k $\Omega$  is connected at the input), the inverter feeds-in. As soon as the input is shorted or opened, the inverter disconnects from the grid.

## Functional description of the terminal

Function	Pin	Definition	Note
Grounding	7	GND.S	Signal GND
DRMs/Logic Interface	8	DRM0	Remotesutdown
	9	DRM1/5	0% power

The Logic interface has to be activated in the LCD screen of the inverter, or with SOFAR View App:

- DRM0 active: Remotesutdown
- DRMn active: active power feed-in limitation function

Also, the power levels in percentage can be adjusted if needed.

### Energy meter connection

To use the feed-in limitation function, a SmartMeter is required to measure the power flow at the point of common coupling (PCC). Refer to below table for the Pin assignments for the RS485 connection between the inverter and the energy meter.

Inverter COM Port Pin	Function	Energy Meter Pin
5	RS485+ (A2)	24
6	RS485- (B2)	25

### Feed-in limitation function

With this function, one single inverter can dynamically limit its output power to keep the feed-in power at the point of common coupling (PCC) below a defined setpoint.

To use the feed-in limitation function, an external SmartMeter has to be connected to measure the power flow at the PCC:

SOFAR Part No.	Product	Type
901.00000048-1	Smart Meter (3-phase, CT's)	Chint DTSU666 1,5(6)A
901.00000058-0	Smart Meter (3-phase inline)	Chint DTSU666 5(80)A

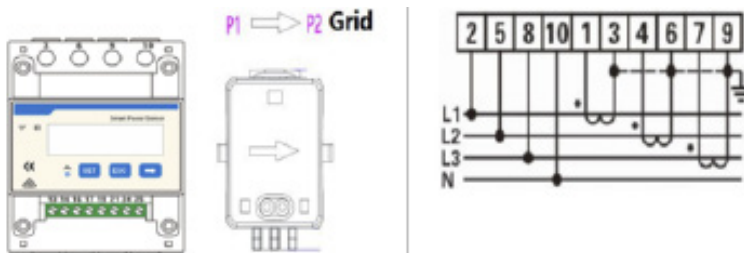

The arrow of the CT's must point to the grid.

There is different feed-in limitation modes available, which can be set in the LCD screen menu:

## Feed-in Limit menu

<b>Feed-in Control</b>	Standard Mode. In case of a communication error with the SmartMeter, the inverter limits its output power to the setpoint.
<b>Hard Feed-in Control</b>	When the Hard Feed-in Control is activated, the inverter shuts down whenever the setpoint is exceeded.
<b>Ctrl. Total Power</b>	Limit the power of the feeding-in phases to the setpoint. Ignore the phases where energy is bought from the grid (standard-setting).
<b>Ctrl. Phase Power</b>	Limit the feed-in power of the sum of all phases to the setpoint (i.e. Germany).
<b>Ctrl. Selling Power</b>	Limit the feed-in power of each phase to 1/3 of the setpoint.

## System monitoring

The SOFAR 100...125KTLX-G4 inverters provide various communication methods for the system monitoring:

RS485 or WiFi stick (standard), GPRS or Ethernet stick (optional).

## RS485 network

You can connect RS485-linked devices to your PC via an RS485 USB adapter or connect them to a data logger.

- The RS485 line may not be any longer than 1000 m.
- Assign each inverter its own modbus address (1 to 31) via the LCD display.
- At the last inverter, put a termination resistor of 120 Ohm between RS485+ and RS485-.

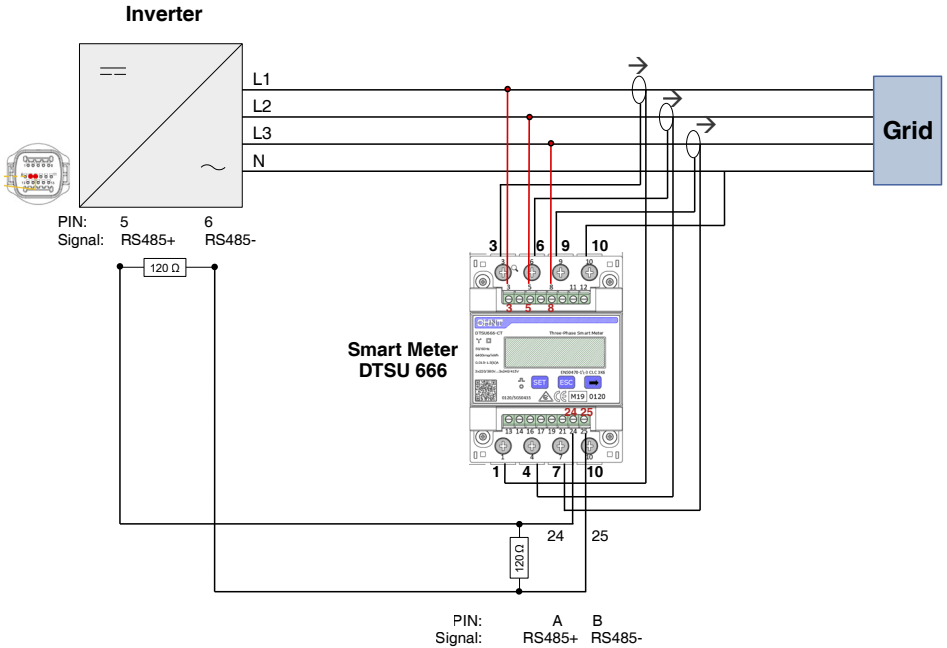
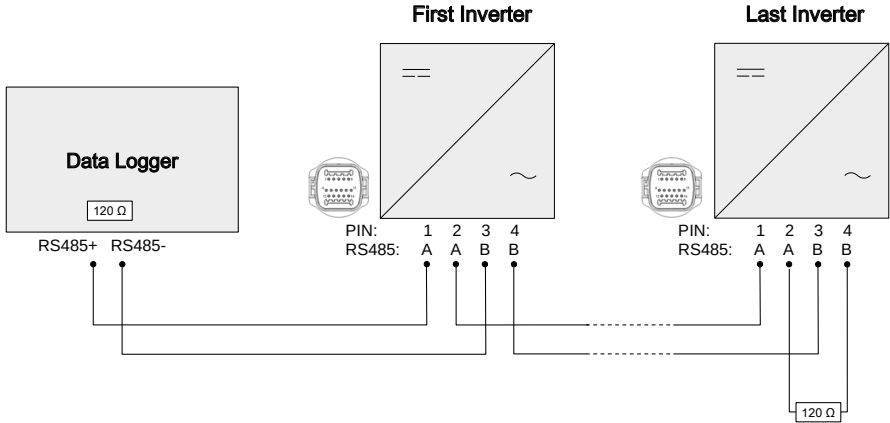

## WiFi, GPRS, Ethernet stick

When you have installed the stick logger, the inverters can directly upload your operating, energy and alarm data in the SolarMAN monitoring portal.

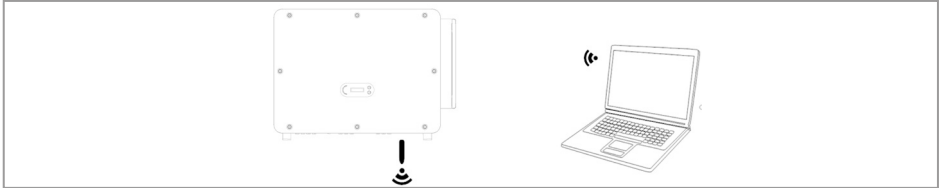

The Stick Loggers are using the outgoing TCP port 10000, which could be blocked in some internet routers

## Configuration of the WiFi stick via the web browser

Preparation: The WiFi stick is installed in accordance with the previous section and the SOFAR inverter must be in operation.

Carry out the following steps in order to configure the WiFi stick:

1. Connect your PC or smartphone with the WiFi network of the WiFi stick. The name of this WiFi network is "AP", followed by the serial number of the WiFi stick (see rating plate). When you are prompted for a password, you can find it on the label of the WiFi stick (PWD).
2. Open an Internet browser and enter the address 10.10.100.254.
- ✓ Recommended browsers: Internet Explorer 8+, Google Chrome 15+, Firefox 10+
3. Enter the username and password, which are both set to "admin" by default. The "Status" page will be opened.
4. Click on the "Wizard" in order to configure the WiFi stick for Internet access.
  - ↳ The WiFi stick begins to send data to SolarMAN.
5. Register your system at the website [home.solarmanpv.com](http://home.solarmanpv.com). For this, enter the serial number found on the stick logger. Installers use the portal at [pro.solarmanpv.com](http://pro.solarmanpv.com).

## Setting up the WiFi stick with the app

To download the app:

- ▶ Search for "SOLARMAN" in the Apple or Google Play store, or use the following QR code: SOLARMAN Smart (for end customers)



# 7 Commissioning

## NOTICE

### Damage of the inverter due to DC / AC voltages outside of permissible range DC / AC voltages outside of permissible range can destroy the inverter

- ▶ Ensure that the DC and AC voltages are within the permissible range of the inverter.
- ▶ AC grid connection: Use multimeter to confirm that three lines and PE line are connect correctly.
- ▶ DC PV connection: Use multimeter to confirm that positive pole and negative pole of PV strings, and the Voc of each string is lower than the inverter max DC input.

## 7.1 Starting the inverter

1. Switch on the DC switch.
2. Switch on the AC circuit breaker.
  - ↳ When the DC output generated by the solar system is at a sufficient level, the inverter starts automatically. A correct operation is indicated by the screen displaying **Normal**.

If the inverter displays an error message, consult chapter [Troubleshooting](#) on page 55 for help.

## 7.2 Initial Setup

When the inverter is started for the first time or after a reset, the following settings must be made:

1. Language
2. Date and Time setting
3. Select Country
4. Select Grid Code

- Different distribution network operators in various countries have differing requirements for the grid connection of grid-coupled PV inverters.
- Ensure that you have selected the correct country code according to regional authority requirements, and consult a qualified electrician or employees of electrical safety authorities.

- SOFARSOLAR is not responsible for the consequences of selecting the incorrect country code.
- The selected country code influences the device grid monitoring. The inverter continuously checks the set limits and, if required, disconnects the device from the grid.

## 7.3 Smartphone app SOFAR setting

The app is available for Android and iOS systems and allows for easy initial setup as well as advanced configurations.

Download link:

IOS	Android
	

After switching on the inverter, the app finds the unit via Bluetooth under its serial number. The App requires an user registration upon first start-up.

On request, the permission level can be adjusted by the SOFAR Service team.

If the Bluetooth connection does not work, carry out a firmware update of the inverter.



# 8 Operation

## 8.1 Control panel and display

### Buttons and display lights



Element	Description
	<b>UP key</b> Short press: Select previous menu item Long press: Exit menu
	<b>DOWN key</b> Short press: Select next menu item Long press: Enter function
LED <b>GFI</b> (red)	Lights up: <b>GFCI fault</b>
LED <b>Normal</b> (green)	Lights up: <b>Normal</b> state Flashes: <b>Wait</b> or <b>Check</b> state
LED <b>Alarm</b> (red)	Lights up: <b>Error</b>

## 8.2 Standard display

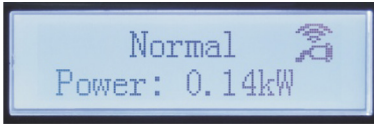

This shows a rolling status display:

1. PV 1 -12 PV input voltage and current
2. PV generated power
3. Today generated electricity
4. Total generated electricity
5. Grid voltage and current
6. Grid voltage and frequency

The WiFi and USB symbol at the upper right corner indicates the connection status.

## 8.3 Status display

The following table displays the various statuses and their meanings:



Status	Description
Initialisation	The control software is started.
Wait	Connecting criteria are checked. The voltage and frequency limits must be within the defined range for a specific duration in accordance with the selected country code.
Check	The inverter checks the insulation resistance, relays and other safety requirements. It will also carry out a self-test to ensure that its software and hardware are functioning faultlessly. If an error or a fault occurs, the inverter will go into the "Fault" or "Permanent" state.
Normal	The inverter goes into the "Normal" state, and feeds current into the grid.
Fault	The inverter goes into the "Fault" state if an error or a fault occurs. It is normally reset automatically by the inverter.
Permanent	Repeated errors can lead to a permanent error which needs investigation and problem solving on site.
DSP communication fault	When the control board and communication board connection fails, the display shows this message.

## 8.4 Menu structure

- ▶ Hold  key to show the main menu.

### Main

Sub menu	What can do here
1. <b>Settings</b>	Change device settings
2. <b>Event list</b>	Display the current event list and the event history
3. <b>System information</b>	Display system information
4. <b>Display time</b>	Display the current system time
5. <b>Software update</b>	Perform a software update

- ▶ Press  or  key to select a sub menu and hold key to open it.

### Settings



Several settings require a password to be entered (the standard password is 0001). When entering the password, press briefly to change the figure and press and hold to confirm the current figure.

1. Set time	Set the system time for the inverter.
2. Clear energy	Clean the inverter of the total power generation.
3. Clear events	Clean up the historical events recorded in the inverter.
4. Set Safe code	The inverter needs to be configured with a specific save code/country code, that will be saved onto a USB drive. Insert the USB drive into the inverter communication port, then long press the button to access the interface, then choose the required country code from the following codes that match your country.
5. Remote Control	Inverter on-off local control.
6. Set Energy	Set the total power generation.
7. Set Address	Set the address (when you need to monitor multiple inverters simultaneously), Default 01.

8. Set input mode	SOFAR 100...125 KTL X-G4 has 10 MPPTs, these MPPTs can work interdependently, or be divided into parallel mode. User can change the setting according to the configuration.
9. Set language	Set the inverter display language.
10. Set Feed-in Limit	This Function enables the inverter to effectively restrict its feed-in power to a pre-set limit, which operates in conjunction with a smart meter that is connected to the inverter.
11. Hard Reflux	This mode disconnects the inverter from the grid if the feed-in limit is exceeded.
12. Logic interface	Enable or disable logical interfaces It is use for below standard Australia (AS47777), Europe General (50549), German(4105).
13. IV Curve Scan	by enabling this function, the peak point of maximum power can be tracked as well as Fault warning, error analysis and localization.
14. Set Power Derate	Set active load shedding function switch, percentage load shedding.
15. PCC Select	Choose the method to detect PCC on-grid point power/current, the electricity meter function( PCC Meter) will also need to be enabled via the menu interface of the inverter.
16. PID Setting	Enable or disable PID function. When the PID module is enabled, it will work between 0 a.m. and 4 a.m. Built-in PID Recovery helps Reduce power loss.
17. Set Baud	Select the protocol type and set the baud rate.
18. GroundDetection	Set ground detection protection.
19. AFCI Setting	Turn on the AFCI ArcDetecEnable function to protect against fires caused by arcing faults in the home electrical wiring.
20. InputSafety	Imports the GridCode Files into the inverter. Put the safety upgrade file "125 KW- G4_SAFETY. bin" in the root Service -General/ firmware folder of the USB flash drive and insert the USB flash drive into the inverter port. choose Enable on. To be sure: go to system info, then press safety, you find the safety code which country entered.
21. SetSafety	After set 4. Set safe code/ 20. Input Safety from the last functions, we could directly choose the country code and set it.

## Event list

The event list is used to display the event recordings. The most recent events are listed at the top.

1. Long press the  key to open **1. Current event**: showing the events in real time.
2. Short press the  key to open **2. History Event**: showing the event history.
  - ↳ The most recent events are listed at the top.

### Example:

- 001 ID04 2023-05-01**
- **001**: Error sequence number
  - **ID04**: Error Code  
(IDs see [Troubleshooting](#) on page 55)
  - **2023-05-01**: time the event took place

## System information

1. Inverter type
2. Serial number
3. General Soft Version
4. General Hard Version
5. Safety
6. SafetySWVer
7. Safety HardVer
8. Modbus Address
9. Input Mode
10. Remote State
11. Reflux Enable
12. Reflux Power
13. DRMs0
14. DRMn
15. Mppt Scan
16. Active Power
17. PCC Select
18. Power Ratio
19. GroundDetection

## 8.5 Software update

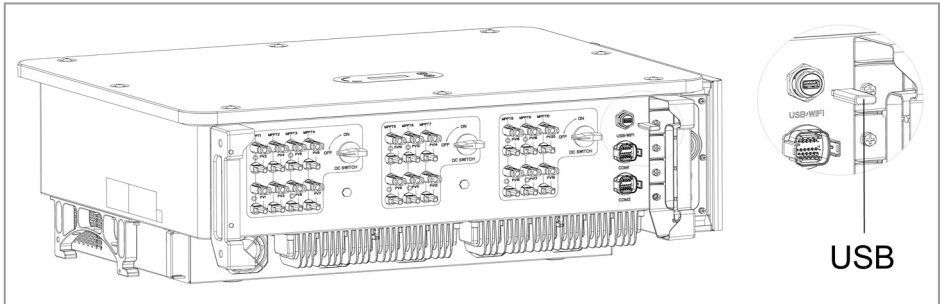

The user can update the software via the USB flash drive. SOFARSOLAR will provide the firmware update when it is required.

1. Switch the DC and AC switches off and then remove the communication cover. If an RS485 line has been connected, ensure that the nut is loosened. Ensure that the communication line is not energised. Remove the cover to prevent the connected communications connector from becoming loose.
2. Insert the USB stick into the computer.
3. SOFARSOLAR will send the firmware update to the user.
4. Unzip the file and copy the original file to a USB stick. Attention: The firmware update file must be in the "firmware" subfolder!
5. Insert the USB flash drive into the USB interface of the inverter.
6. Switch on the DC switch and go to menu item "5. Software update" on the LCD display.
7. Enter the password (the standard password is 0715).
8. The system will then successively update the main DSP, auxiliary DSP and ARM processors. Pay attention to the displays.
9. If an error message appears, switch off the DC switch and wait until the LCD screen goes out. Then, switch the DC switch back on and proceed with the update from step 5.
10. After the update is complete, switch the DC switch off and wait until the LCD screen goes out.
11. Re-establish a watertight communication connection.
12. Switch the DC and AC circuit breaker back on.
13. You can check the current software version in item "3. Software version" of the SystemInfo menu.

# 9 Troubleshooting

This section contains information and procedures pertaining to the remedying of potential problems with the inverter.

**To carry out troubleshooting, proceed as follows:**

- ▶ Check the warnings, error messages or error codes displayed on the screen of the inverter.
- ▶ If no error information is displayed on the screen, check whether the following requirements have been fulfilled:
  - ✓ Has the inverter been set up in a clean, dry, well-ventilated area?
  - ✓ Is the DC switch set to ON?
  - ✓ Are the cables sufficiently dimensioned and short enough?
  - ✓ Are the input connections, output connections and the wiring all in good condition?
  - ✓ Are the configuration settings for the relevant installation correct?
  - ✓ Are the display field and the communication cables correctly connected and undamaged?

**Proceed as follows to display the recorded problems:**

1. Hold the button down to bring up the main menu of the standard interface.
2. Select "2. Event list" and hold the button down to bring up the event list.

## 9.1 Ground fault alarm

This inverter is compliant with IEC 62109-2 Clause 13.9 for earth fault protection.

If an earth fault alarm occurs, the error is displayed on the LCD screen, the red light illuminates and the error can be found in the error history log.

In the case of devices equipped with a stick logger, the alarm information can be viewed on the monitoring portal and retrieved via the smartphone app.

## 9.2 Event list

ID	Name	Description	Solution
01	GridOVP	The voltage of the power grid is too high	<p>If the alarm occurs occasionally, the possible cause is that the electric grid is abnormal occasionally. Inverter will automatically return to normal operating status when the electric grid's back to normal.</p> <p>If the alarm occurs frequently, check whether the grid voltage/frequency is within the acceptable range. If yes, check the AC circuit breaker and AC wiring of the inverter.</p> <p>If the grid voltage/frequency is NOT within the acceptable range and AC wiring is correct, but the alarm occurs repeatedly, contact technical support to change the grid over-voltage, under-voltage, over-frequency, under-frequency protection points after obtaining approval from the local electrical grid operator.</p>
02	GridUVP	The voltage of the power grid is too low	
03	GridOFP	The grid frequency is too high	
04	GridUFP	The grid frequency is too low	
05	GFCI	Charge Leakage Fault	Check for inverter and wiring.



ID	Name	Description	Solution
06	OVRT	OVRT function disrupted	<p>If the alarm occurs occasionally, the possible cause is that the electric grid is abnormal occasionally. Inverter will automatically return to normal operating status when the electric grid's back to normal.</p> <p>If the alarm occurs frequently, check whether the grid voltage/frequency is within the acceptable range. If yes, check the AC circuit breaker and AC wiring of the inverter.</p> <p>If the grid voltage/frequency is NOT within the acceptable range and AC wiring is correct, but the alarm occurs repeatedly, contact technical support to change the grid over-voltage, under-voltage, over-frequency, under-frequency protection points after obtaining approval from the local electrical grid operator.</p>
07	LVRT	LVRT function disrupted	
08	IslandFault	Island protection error	
09	GridOVPIInstant1	The input voltage is too high	
10	GridOVPIInstant2	Input current is not symmetrical	
11	VGridLineFault	Power grid line voltage error	
12	InvVoltFault	Inverter voltage error	<p>Internal faults of inverter, switch OFF inverter, wait for 5 minutes, then switch ON inverter. Check whether the problem is solved. If no, contact technical support.</p>
13	RefluxFault	Anti-countercurrent overload	

ID	Name	Description	Solution
14	VGridUnbalance	grid voltage imbalance	
17	HwADerrlGrid	Power grid current sampling error	
18	HwADerrDCI(AC)	Wrong sampling of dc component of grid current	
19	HwADerrVGrid(DC)	Power grid voltage sampling error (DC)	
20	HwADerrVGrid(AC)	Power grid voltage sampling error (AC)	
21	HwGFCIFault(DC)	Leakage current sampling error(DC)	
22	HwGFCIFault(AC)	Leakage current sampling error(AC)	
24	HwADerrldc	Dc input current sampling error	
25	HwADerrDCI(DC)	/	
26	HwADerrldcBranch	/	
29	ConsistentGFCI	Leakage current consistency error	Internal faults of inverter, switch OFF inverter, wait for 5 minutes, then switch ON inverter. Check whether the problem is solved. If no, contact technical support.
30	ConsistentVgrid	Grid voltage consistency error	
31	ConsistentDCI	DCI consistency error	
33	SpiCommFault(DC)	SPI communication error (DC)	
34	SpiCommFault(AC)	SPI communication error (AC)	
35	SChip_Fault	Chip error (DC)	

ID	Name	Description	Solution
36	MChip_Fault	Chip error (AC)	
37	HwAuxPowerFault	Auxiliary power error	
38	InvSoftStartFail	Inverter soft startup failed	
39	ArcShutdownAlarm	Arc shutdown protection	Check whether the photovoltaic module connection line and terminals have bad arc contact. If there is a fault, repair the fault in ti
41	RelayFail	Relay detection failure	Internal faults of inverter, switch OFF inverter, wait for 5 minutes, then switch ON inverter. Check whether the problem is solved. If no, contact technical support.
42	IsoFault	Low insulation impedance	Check the insulation resistance between the photovoltaic array and ground (ground), if there is a short circuit, the fault should be repaired in time.
43	PEConnectFault	Ground fault	Check ac output PE wire for grounding.
44	PvConfigError	Error setting input mode	Check the input mode (parallel/independent mode) Settings for the inverter. If not, change the input mode.
46	ReversalConnect	PV input polarity reverse connection error	Connect the PV assembly according to the correct polarity.

ID	Name	Description	Solution
50	TempErrHeatSink1	Radiator 1 temperature protection	<p>For Inner BMS battery, make sure that the battery NTC cable is properly connected. Make sure the inverter is installed where there is no direct sunlight.</p> <p>Ensure that the inverter is installed in a cool/well ventilated place. Ensure the inverter is installed vertically and the ambient temperature is below the inverter temperature limit.</p>
51	TempErrHeatSink2	Radiator 2 temperature protection	
52	TempErrHeatSink3	Radiator 3 temperature protection	
53	TempErrHeatSink4	Radiator 4 temperature protection	
54	TempErrHeatSink5	Radiator 5 temperature protection	
55	TempErrHeatSink6	Radiator 6 temperature protection	
57	TempErrEnv1	Ambient temperature 1 protection	
58	TempErrEnv2	Ambient temperature 2 protection	
59	TempErrInv1	Module 1 temperature protection	
60	TempErrInv2	Module 2 temperature protection	
61	TempErrInv3	Module 3 temperature protection	
62	TempDiffErrInv	Inverter Module Temperature Difference is too large	
65	BusRmsUnbalance	Unbalanced bus voltage RMS	
66	BusInstUnbalance	The transient value of bus voltage is unbalanced	

ID	Name	Description	Solution
67	BusUVP	Busbar undervoltage during grid-connection	
68	BusZVP	Bus voltage low	
69	PVOVP	PV over-voltage	Check whether the PV series voltage (Voc) is higher than the maximum input voltage of the inverter. If so, adjust the number of PV modules in series and reduce the PV series voltage to fit the input voltage range of the inverter. After correction, the inverter will automatically return to its normal state.
71	LLCBusOVP	LLC BUS overvoltage protection	Internal faults of inverter, switch OFF inverter, wait for 5 minutes, then switch ON inverter. Check whether the problem is solved. If no, contact technical support.
72	SwBusRmsOVP	Inverter bus voltage RMS software over-voltage	
73	SwBusIOVP	Inverter bus voltage instantaneous value software overvoltage	
82	DciOCP	Dci overcurrent protection	
83	SwIOCP	Output instantaneous current protection	
84	SwBuckBoostOCP	BuckBoost software flow	
85	SwAcRmsOCP	Output effective value current protection	

ID	Name	Description	Solution
86	SwPvOCPInstant	PV overcurrent software protection	Internal faults of inverter, switch OFF inverter, wait for 5 minutes, then switch ON inverter. Check whether the problem is solved. If no, contact technical support.
87	IpvUnbalance	PV flows in uneven parallel	
88	IacUnbalance	Unbalanced output current	
89	SwPvOCP	PV overcurrent software protection	
90	IbalanceOCP	Inverter bus balance current protection	
91	SwAcCBCFault	Software AC Over Current Protection	
98	HwBusOVP	Inverter bus hardware overvoltage	
99	HwBuckBoostOCP	BuckBoosthardware overflows	
102	HwPVOCP	PV hardware overflows	
103	HwACOCP	Ac output hardware overflows	
104	HwDiffOCP	Hardware differential over-current	
105	MeterCommFault	Meters communication fault	Check whether the meters wiring is correct.
113	OverTempDerating	Internal temperature is too high	Make sure the inverter is installed where there is no direct sunlight. Ensure that the inverter is installed in a cool/well ventilated place. Ensure the inverter is installed vertically and the ambient temperature is below the inverter temperature limit.

ID	Name	Description	Solution
114	FreqDerating	AC frequency is too high	Make sure the grid frequency and voltage is within the acceptable range.
115	FreqLoading	AC frequency is too low	
116	VoltDerating	AC voltage is too high	
117	VoltLoading	AC voltage is too low	
129	PermHwAcOCP	Output hardware overcurrent permanent failure	Internal faults of inverter, switch OFF inverter, wait for 5 minutes, then switch ON inverter. Check whether the problem is solved. If no, contact technical support.
130	PermBusOVP	Permanent Bus overvoltage failure	
131	PermHwBusOVP	Permanent Bus hardware overvoltage failure	
132	PermlpvUnbalance	PV uneven flow permanent failure	
134	PermAcOCPInstant	Output transient overcurrent permanent failure	
135	PermlacUnbalance	Permanent failure of unbalanced output current	
137	PermInCfgError	Input mode setting error permanent failure	Check the PV input mode (parallel/independent mode) Settings for the inverter. If not, change the PV input mode.
138	PermDCOCPInstant	Input overcurrent permanent fault	

ID	Name	Description	Solution
139	PermHwDCOCP	Permanent relay failure	Internal faults of inverter, switch OFF inverter, wait for 5 minutes, then switch ON inverter. Check whether the problem is solved. If no, contact technical support.
140	PermRelayFail	Bus voltage unbalanced	
141	PermBusUnbalance	permanent failure	
142	PermSpdFail(DC)	PV surge protection	
143	PermSpdFail(AC)	Grid surge protection	
145	USBFault	USB fault	Check the USB port of the inverter
146	WifiFault	WiFi fault	Check the WiFi port of the inverter
147	BluetoothFault	Bluetooth fault	Check the bluetooth connection of the inverter
148	RTCFault	RTC clock failure	Internal faults of inverter, switch OFF inverter, wait for 5 minutes, then switch ON inverter. Check whether the problem is solved. If no, contact technical support.
149	CommEEPROM-Fault	Communication board EEPROM error	
150	FlashFault	Communication board FLASH error	
152	SafetyVerFault	The software version is inconsistent with the safety version	
153	SCILose(DC)	SCI communication error (DC)	
154	SCILose (AC)	SCI communication error (AC)	Contact for technical support and software upgrades
155	SCILose (Fuse)	SCI communication error (Fuse)	
156	SoftVerError	Inconsistent software versions	
161	ForceShutdown	Force shutdown	The inverter is performed a forced shutdown
162	RemoteShutdown	Remote shutdown	The inverter is performed with a Drms0 shutdown



ID	Name	Description	Solution
163	Drms0Shutdown	Drms0 shutdown	The inverter is performed a remote shutdown
165	RemoteDerating	Remote derating	The inverter is performed for remote load reduction
166	LogicIcfDerating	Logic interface derating	The inverter is loaded by the execution logic interface
167	AlarmAntiReflux	Anti refluxderating	The inverter is implemented to prevent countercurrent load drop
169	FanFault1	Fan 1 fault	Check whether the fan 1 of inverter is running normally
170	FanFault2	Fan 2fault	Check whether the fan 2 of inverter is running normally
171	FanFault3	Fan 3 fault	Check whether the fan 3 of inverter is running normally
172	FanFault4	Fan 4 fault	Check whether the fan 4 of inverter is running normally
173	FanFault5	Fan 5 fault	Check whether the fan 5 of inverter is running normally
174	FanFault6	Fan 6 fault	Check whether the fan 6 of inverter is running normally
175	FanFault7	Fan 7 fault	Check whether the fan 7 of inverter is running normally
176	MeterCommLose	Meters communication fault	Check whether the meters wiring is correct
189	AFCICommLose	AFCI module communication is lost	
191	PID_Output_Fail	PID function is failed	
192	PLC_Com_Fail	PLC communication is lost	Check whether the meters wiring is correct

# 10 Maintenance

Inverters do not generally require daily or routine maintenance. Before carrying out cleaning, ensure that the DC switch and AC circuit breaker between the inverter and power grid have been switched off. Wait at least 5 minutes before carrying out cleaning.

## 10.1 Cleaning the inverter

Clean the inverter using an air blower and a dry, soft cloth or a soft bristle brush. Do NOT clean the inverter with water, corrosive chemicals, cleaning agents etc.

## 10.2 Cleaning the heat sink

In order to help guarantee correct long-term operation of the inverter, make sure that there is sufficient space for ventilation around the heat sink. Check the heat sink for blockages (dust, snow etc.) and remove them if present. Clean the heat sink using an air blower and a dry, soft cloth or a soft bristle brush. Do NOT clean the heat sink with water, corrosive chemicals, cleaning agents etc.

## 10.3 Fan maintenance and replacing a fan

Fans must be cleaned and maintained regularly for both performance and safety concerns.

### DANGER

**Dangerous electric voltage inside the housing**

**Touching exposed parts can lead to an electric shock and death.**

- ▶ Disconnect the device from the power supply before removing the fan module.
- ▶ Wait at least 5 min after disconnecting before start working on the inverter.

### NOTICE

**Defective or dirty fans can reduce the performance of the inverter**

**Broken or faulty fans may cause cooling issues, which may lead to limited heat dissipation and a lower working efficiency of the inverter.**

- ▶ Clean fans regularly.

Follow below steps for replacing a fan and maintenance:

1. Remove the screw (1) from the fan tray and store them properly.
2. Pull out the fan tray until the fan baffle plate aligns with the SOFAR inverter enclosure.
3. Unscrew the connectors and disconnect the cables.
4. Pull out the fan tray.

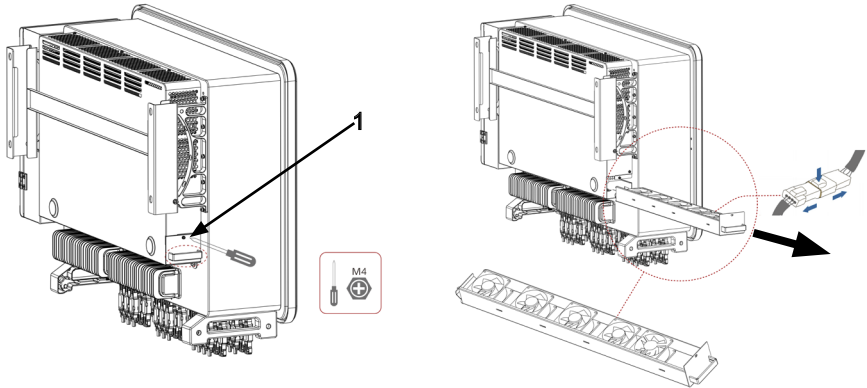

5. Remove the cable ties from the faulty fan.
6. Install a new fan.

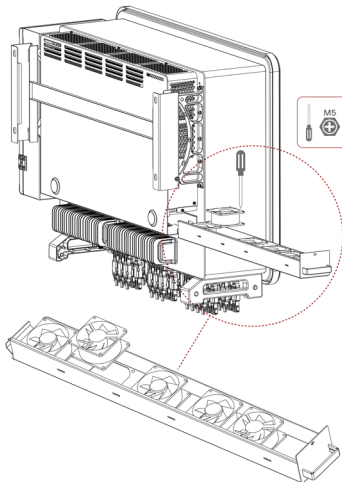

7. Bind the fan cables.
8. Clean the fan tray and ensure that no foreign matter is left.

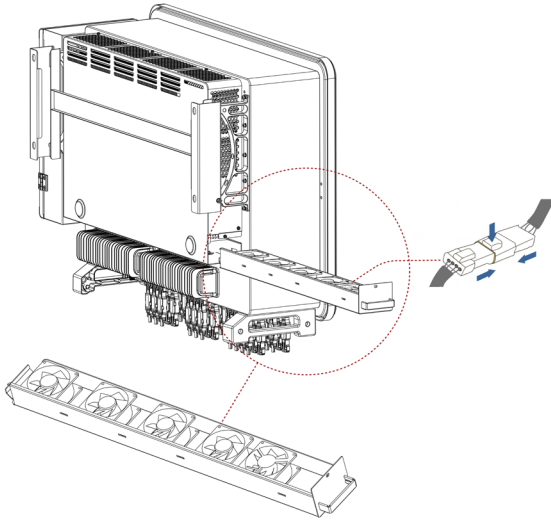

- 9. Align the fan tray with the installation position and push in the fan tray until the fan baffle plate is flush with the SOFAR inverter enclosure.
- 10. Connect the cables correctly according to the cable labels.
- 11. Tighten the screw (1) on the fan tray.

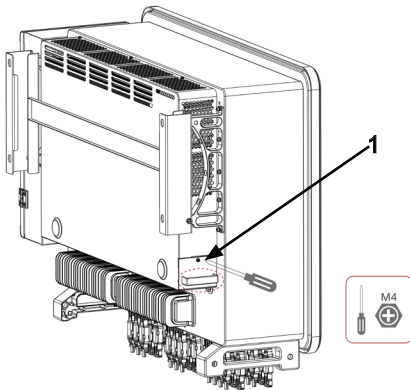

# 11 Technical Data

Datasheet	SOFAR 100KTLX-G4	SOFAR 110KTLX-G4	SOFAR 125KTLX-G4	SOFAR 125KTLX-G4-A
<b>Input DC</b>				
Max. input voltage	1100 V			
Rated input voltage	625 V			
Start-up voltage	200 V			
MPPT operating voltage range	180 – 1000 V			
Number of MPP trackers	10			
Number of DC inputs	20			
Max. input MPPT current	10 – 40 A			
Max. input short circuit current	10 – 50 A			
<b>Output (AC)</b>				
Rated output power	100 kW	100 kW	110 kW	125 kW
AC output power	100 kVA @ 45 °C 90 kVA @ 50 °C	110 kVA @ 45 °C 100 kVA @ 50 °C	125 kVA @ 45 °C 110 kVA @ 50 °C	125 kVA @ 45 °C 110 kVA @ 50 °C
Max. Output current	152 A @ 380 V 145 A @ 400 V 139.2 A @ 415 V	167.2 A @ 380 V 159.5 A @ 400 V 153.1 A @ 415 V	190 A @ 380 V 181.2 A @ 400 V 174 A @ 415 V	190 A @ 380 V 181.2 A @ 400 V 174 A @ 415 V
Rated grid voltage	3/N/PE, 380 V / 400 V / 415 V			
Grid voltage range	310 – 480 V			
Rated frequency	50/60 Hz			
Grid frequency range	45 – 55Hz / 55 – 65 Hz			
Active power adjustable range	0 – 100 %			
THDi	<1 % (@100 %P)			
Power factor	1 default (+/-0.8 adjustable)			
Initial short-circuit AC current	756.7 A-peak			
<b>Efficiency</b>				

Datasheet	SOFAR 100KTLX-G4	SOFAR 110KTLX-G4	SOFAR 125KTLX-G4	SOFAR 125KTLX-G4-A
Max efficiency	98.60 %			
European efficiency	98.30 %			
<b>Protection</b>				
DC reverse polarity protection	Yes			
Anti-islanding protection	Yes			
Leakage current protection	Yes			
Ground fault monitoring	Yes			
PV-array string fault monitoring	Yes			
DC switch	Yes			
PID recovery	Yes			
AFCI	Yes			
SPD	PV: type II Standard / AC: type II Standard			
<b>General Data</b>				
Ambient temperature range	-30 – +60 °C			
Storage conditions	Temp. -40 – 70 °C / rel. humidity 0 – 95 %, no condensation			
Topology	Transformerless			
Degree of protection	IP66			
Allowable relative humidity range	0 – 100 %			
Max. operating altitude	4000 m (>3000 m derating)			
Weight	75 kg			
Cooling	Smart air cooling			
Dimension (W x H x D)	970 x 695 x 325 mm			
Display	LCD & Bluetooth +APP			
Communication	RS485 / WiFi / Bluetooth, optional Ethernet			

# 11.1 Efficiency Curves

## Efficiency

This describes the efficiency curve in which the minimum MPP voltage (UDCMIN = 500 V), the maximum MPP voltage (UDCMAX = 850 V) and the rated input voltage (UDC, R = 625 V) of SOFAR 100...125KTLX-G4, including SOFAR 100KTLX-G4, SOFAR 110KTLX-G4, SOFAR 125KTLX-G4 (hereinafter referred to as 100KTLX-G4, 110KTLX-G4, 125KTLX-G4).

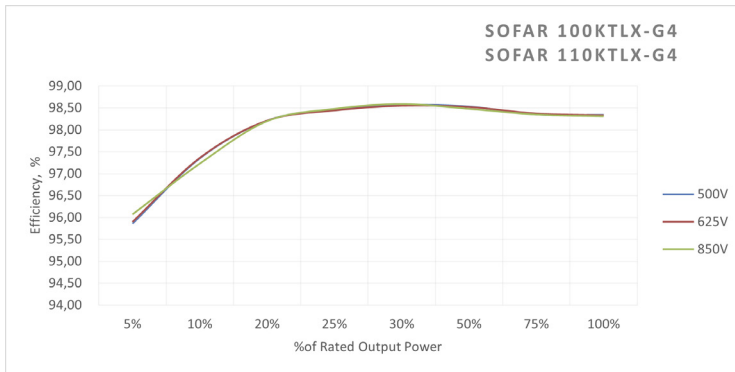

- Max. efficiency                    98.6 %
- European efficiency            98.3 %

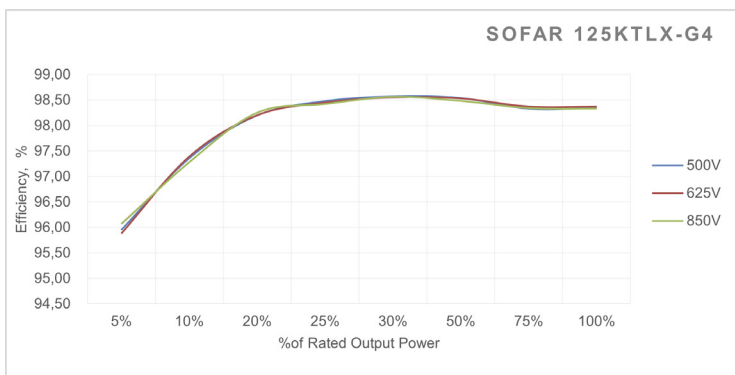

- Max. efficiency                    98.6 %
- European efficiency            98.3 %

## 11.2 Characteristics curves

This describes the characteristics curves of SOFAR 110-125KTLX-G4, including SOFAR 110KTLX-G4, SOFAR 125KTLX-G4 (hereinafter referred to as 110KTLX-G4,125KTLX-G4).

### Temperature dependent derating curve

The inverter will output different power in different environments, which can increase the overall service life of the inverter. Therefore, when the ambient temperature is high, the inverter will appropriately reduce the output power to ensure safe and long-term operation.

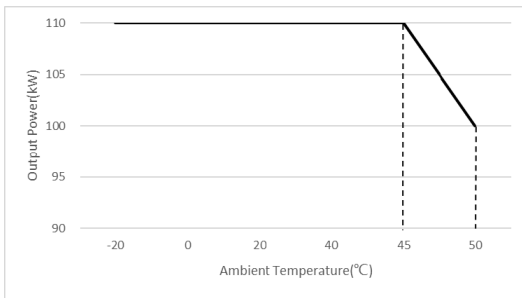

SOFAR 110KTLX-G4 Temperature dependent derating curve

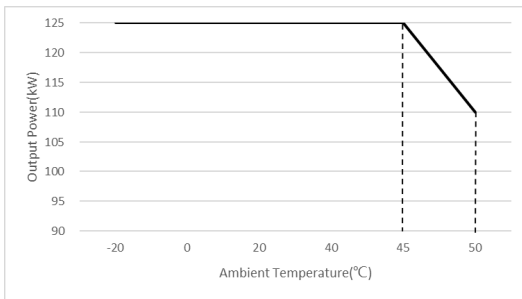

SOFAR 125KTLX-G4 Temperature dependent derating curve



### Description of load reduction under different input voltage conditions

The inverter will output different load reduction under different input voltages. When the input voltage is 500 V – 850 V, the inverter can ensure sufficient power output. With the higher input voltage, the power will gradually decrease to ensure the long-term reliable operation of the machine. It is recommended that the user input the rated voltage at 625 V and the open circuit voltage at 890 V to make the inverter output with the best efficiency and obtain the best power generation.

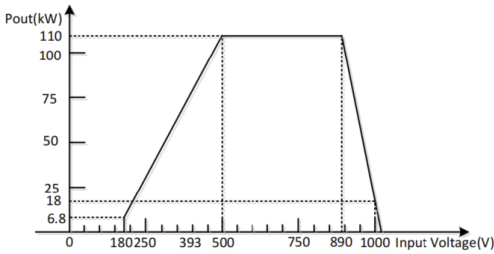

SOFAR 110KTLX-G4 DC voltage dependent output power derating curve (Pf=1)

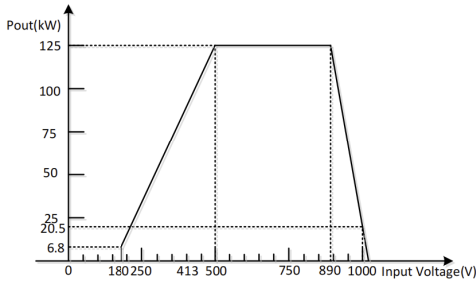

SOFAR 125KTLX-G4 DC voltage dependent output power derating curve (Pf=1)

## AC voltage derating curve

The operating voltage range of the inverter is 310 V – 480 V, and the rated voltage is 380 V / 400 V / 415 V. When the grid voltage drops ( $VAC > 310 V$ ), the inverter will reduce the output power. This condition may lead to overheating of some parts of the inverter, resulting in potential risks such as overheating and overload. In this case, the inverter automatically adjusts the output power according to the grid voltage to ensure that the AC output current is within the allowable range and ensure the safe operation of the equipment. It is generally recommended that the user configure it at the rated voltage of 380 VAC / 400 VAC / 415 VAC to obtain the maximum generating energy.

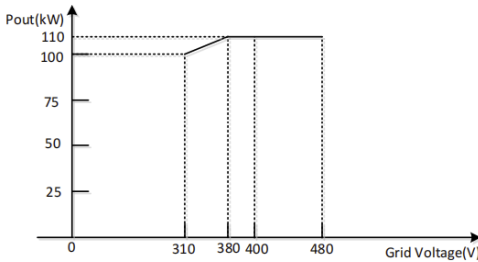

SOFAR 110KTLX-G4 AC Voltage Dependent Derating Curve (Pf=1)

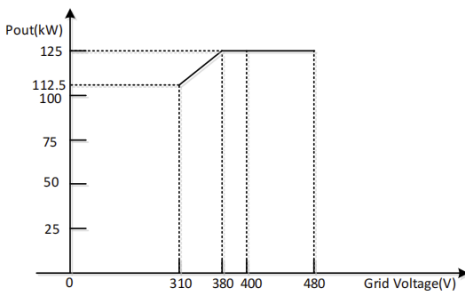

SOFAR 125KTLX-G4 AC Voltage Dependent Derating Curve (Pf=1)

### Altitude dependent derating curve

In high-altitude areas, the air density is low, and charged particles are more vulnerable to ionization in thin air. When the gap and creepage distance between internal components of the inverter are fixed, It is necessary to limit the DC voltage according to the following curve in the design stage of the power station to ensure electrical safety.

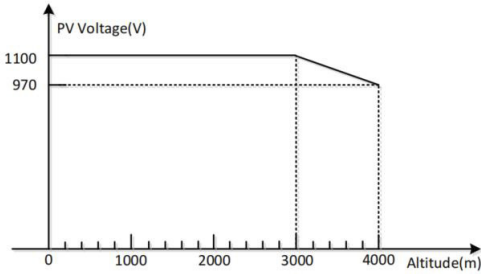

Altitude Dependent Derating Curve [Voltage derating] (Pf=1)

### Statement

There are many uncertainties in practical applications which may lead to differences between actual use and test data.

Therefore, this information is provided for reference purpose, SOFARSOLAR may change the information at any time without notice.

# 12 Declaration of Conformity

Hereby, SOFARSOLAR declares that the radio equipment type  
SOFAR 100...125KTLX-G4 is in compliance with Directive 2014/53/EU.

The full text of the EU declaration of conformity is available at the following web address: [www.sofarsolar.com](http://www.sofarsolar.com)





ENERGY TO POWER YOUR LIFE

**ADDRESS**

Shenzhen SOFARSOLAR Co., Ltd.  
11/F, Gaoxinqi Technology Building,  
District 67, XingDong Community, XinAn Street,  
Bao'An District, Shenzhen, China

**EMAIL**

[info@sofarsolar.com](mailto:info@sofarsolar.com)

**Website**

[www.sofarsolar.com](http://www.sofarsolar.com)

SOFARSOLAR 

